



## **505CC-2 Steam Turbine and Compressor Control**

**Volume 3, Compressor Control Manual  
INACTIVE Part Number 8701-1114  
(current P/N is 8701-1356, in manual 26451)**

Manual 26240 consists of 4 volumes (26240V1, 26240V2, 26240V3, & 26240sup).

**Configuration and Operation Manual**



### General Precautions

Read this entire manual and all other publications pertaining to the work to be performed before installing, operating, or servicing this equipment.

Practice all plant and safety instructions and precautions.

Failure to follow instructions can cause personal injury and/or property damage.



### Revisions

This publication may have been revised or updated since this copy was produced. To verify that you have the latest revision, check manual **26311**, *Revision Status & Distribution Restrictions of Woodward Technical Publications*, on the *publications page* of the Woodward website:

[www.woodward.com/publications](http://www.woodward.com/publications)

The latest version of most publications is available on the *publications page*. If your publication is not there, please contact your customer service representative to get the latest copy.



### Proper Use

Any unauthorized modifications to or use of this equipment outside its specified mechanical, electrical, or other operating limits may cause personal injury and/or property damage, including damage to the equipment. Any such unauthorized modifications: (i) constitute "misuse" and/or "negligence" within the meaning of the product warranty thereby excluding warranty coverage for any resulting damage, and (ii) invalidate product certifications or listings.



### Translated Publications

If the cover of this publication states "Translation of the Original Instructions" please note:

The original source of this publication may have been updated since this translation was made. Be sure to check manual **26311**, *Revision Status & Distribution Restrictions of Woodward Technical Publications*, to verify whether this translation is up to date. Out-of-date translations are marked with . Always compare with the original for technical specifications and for proper and safe installation and operation procedures.

**Revisions**—Changes in this publication since the last revision are indicated by a black line alongside the text.

Woodward reserves the right to update any portion of this publication at any time. Information provided by Woodward is believed to be correct and reliable. However, no responsibility is assumed by Woodward unless otherwise expressly undertaken.

# Contents

<b>WARNINGS AND NOTICES .....</b>	<b>IV</b>
<b>ELECTROSTATIC DISCHARGE AWARENESS .....</b>	<b>V</b>
<b>CHAPTER 1. GENERAL INFORMATION.....</b>	<b>1</b>
Introduction .....	1
Quick Start Guide .....	1
<b>CHAPTER 2. COMPRESSOR CONTROL OVERVIEW.....</b>	<b>2</b>
Introduction .....	2
What is Surge? .....	2
Functional Overview .....	3
Anti-Surge Control Theory.....	7
Standard Compressor Performance Map.....	7
Universal Compressor Performance Map .....	9
Standard or Universal Algorithm? .....	12
S_PV (Surge Process Variable) .....	12
505CC-2 Anti-Surge Control Description .....	13
Operating Point Calculations .....	41
<b>CHAPTER 3. COMPRESSOR CONTROL GENERAL DESCRIPTION.....</b>	<b>47</b>
Introduction .....	47
Additional Features.....	47
505CC-2 Inputs and Outputs.....	48
Anti-Surge Control Recommendations .....	50
<b>CHAPTER 4. COMPRESSOR CONFIGURATION OVERVIEW .....</b>	<b>51</b>
Introduction .....	51
505CC-2 Compressor Configuration Screens.....	52
Compressor General Screen .....	52
Stage 1 Open Loop Screen (same for Stage 2) .....	56
Stage 1 Closed Loop Screen (same for Stage 2).....	59
Stage 1 I/O Screen (same for Stage 2) .....	62
Compressor Discretes Screen.....	65
Compressor Analogs Screen.....	66
Compressor Standard Map Tool Screen .....	69
Compressor Universal Map Tool Screen.....	72
Loop Period Test Procedure.....	75
Dynamics Adjustments .....	76
<b>CHAPTER 5. COMPRESSOR OPERATION OVERVIEW.....</b>	<b>79</b>
Introduction .....	79
Compressor Operation .....	79
505CC-2 Compressor Operating Screens .....	81
<b>CHAPTER 6. SERVICE OPTIONS .....</b>	<b>90</b>
Product Service Options.....	90
Woodward Factory Servicing Options .....	91
Returning Equipment for Repair .....	91
Replacement Parts .....	92
Engineering Services.....	92
How to Contact Woodward.....	93
Technical Assistance.....	93
<b>APPENDIX A. VALID COMPRESSOR CONFIGURATIONS .....</b>	<b>94</b>
<b>APPENDIX B. ATMOSPHERIC PRESSURE CHART.....</b>	<b>102</b>

## Illustrations and Tables

Figure 2-1. Typical Compressor Application .....	2
Figure 2-2. Surge Cycle.....	3
Figure 2-3. Overview of 505CC-2 Functionality Notes .....	4
Figure 2-4a. Overview of 505CC-2 Anti-Surge Control Functionality.....	5
Figure 2-4b. Overview of 505CC-2 Anti-Surge Control Functionality.....	6
Figure 2-5. Standard Compressor Map .....	7
Figure 2-6. Process Control Diagram .....	8
Figure 2-7. Universal Compressor Map .....	10
Figure 2-8. Process Control Diagram .....	11
Figure 2-9. Compressor Map S_PV Regions .....	13
Figure 2-10. Mode Select .....	14
Figure 2-11. Manual Setting of Anti-surge Valve.....	15
Figure 2-12. On-Line Detection .....	17
Figure 2-13. Anti-Surge Functions.....	18
Figure 2-14. Surge Detection and Counter .....	19
Figure 2-15. Surge Recovery and Surge Minimum Position (SMP).....	21
Figure 2-16. Anti-surge Valve Response to a Surge .....	21
Figure 2-17. BOOST / Valve Step Opening .....	22
Figure 2-18. Anti-Surge PID .....	23
Figure 2-19. Rate Controller PID .....	23
Figure 2-20. Automatic Gain Compensation .....	25
Figure 2-21. Anti-Surge Decoupling .....	26
Figure 2-22. Effect of Valve Layout on Adjacent Stage Decoupling Amounts .....	28
Figure 2-23. Pressure Override Control .....	29
Figure 2-24. Auxiliary Control Variables .....	30
Figure 2-25. Analog 4–20 mA Input Signal Filtering and Failure Monitoring .....	32
Figure 2-26. Input Signal Configure and Failure Response .....	33
Figure 2-27. Valve Position Freeze Routine.....	35
Figure 2-28. Valve Overstroke.....	35
Figure 2-29. Valve Dither.....	36
Figure 2-30. Valve Characterization .....	37
Figure 2-31. BOOST Response with Pre-Pack .....	37
Figure 2-32. Gas Property Calculations .....	38
Figure 4-1. Configuration Menu Screen .....	51
Figure 4-2. Compressor General Configuration Screen.....	53
Figure 4-3. Example Compressor Layouts.....	54
Figure 4-4. Dual with 2 Flow Element Layouts.....	55
Figure 4-5. Dual with SideStream Layouts.....	55
Figure 4-6. Open Loop Configuration Screen .....	56
Figure 4-7. Compressor Closed Loop Configuration Screen .....	60
Figure 4-8. Compressor I/O Configuration Screen.....	62
Figure 4-9. Compressor Discretes Configuration Screen .....	65
Figure 4-10. Discrete Output Forcing Pop-Up.....	66
Figure 4-11. Compressor Analogs Configuration Screen .....	66
Figure 4-12. Compressor Analog Calibration Pop-Up.....	67
Figure 4-13. Analog Output Calibration Pop-Up.....	68
Figure 4-14. Analog Output Calibration Pop-Up.....	69
Figure 4-15. Standard Map Tool Data Entry Screen .....	70
Figure 4-16. Standard Map Output Screen .....	72
Figure 4-17. Universal Map Tool Data Entry Screen.....	73
Figure 4-18. Universal Map Output Screen.....	74
Figure 4-19. Typical Response to Load Change.....	78

## Illustrations and Tables

Figure 5-1. Main Menu Screen .....	80
Figure 5-2. Compressor Operation Screen .....	82
Figure 5-3. Compressor Stage Operation Screen.....	83
Figure 5-4. Compressor Logic Diagram Screen.....	85
Figure 5-5. Compressor Anti-Surge PID Tuning Screen.....	86
Figure 5-6. Compressor Map Screen .....	87
Figure 5-7. Compressor Map Adjust Pop-Up .....	87
Figure 5-8. Compressor Anti-surge Valve Linearization Screen.....	89
Figure A-1. Standard Algorithm, Single Stage Configurations.....	94
Figure A-2a. Standard Algorithm, Dual with 1 Flow Element Configurations.....	95
Figure A-2b. Standard Algorithm, Dual with 1 Flow Element Configurations.....	96
Figure A-3a. Standard Algorithm, Dual with 2 Flow Element Configurations.....	97
Figure A-3b. Standard Algorithm, Dual with 2 Flow Element Configurations.....	98
Figure A-4. Standard Algorithm, Dual with SideStream Configurations.....	99
Figure A-5. Universal Algorithm, Single Stage Configurations.....	100
Figure A-6. Universal Algorithm, Dual with 2 Flow Element Configurations .....	100
Figure A-7. Universal Algorithm, Dual with SideStream Configurations .....	101
Table 2-1. Input Signal Failure Response Sequences.....	34
Table 2-2. Compressor Alarm List.....	39
Table 2-3. 505CC-2 Compressor Datalog.....	40
Table B-1. Atmospheric Pressure Chart.....	102

# Warnings and Notices

## Important Definitions



This is the safety alert symbol. It is used to alert you to potential personal injury hazards. Obey all safety messages that follow this symbol to avoid possible injury or death.

- **DANGER**—Indicates a hazardous situation which, if not avoided, will result in death or serious injury.
- **WARNING**—Indicates a hazardous situation which, if not avoided, could result in death or serious injury.
- **CAUTION**—Indicates a hazardous situation which, if not avoided, could result in minor or moderate injury.
- **NOTICE**—Indicates a hazard that could result in property damage only (including damage to the control).
- **IMPORTANT**—Designates an operating tip or maintenance suggestion.

### **WARNING**

**Overspeed /  
Overtemperature /  
Overpressure**

The engine, turbine, or other type of prime mover should be equipped with an overspeed shutdown device to protect against runaway or damage to the prime mover with possible personal injury, loss of life, or property damage.

The overspeed shutdown device must be totally independent of the prime mover control system. An overtemperature or overpressure shutdown device may also be needed for safety, as appropriate.

### **WARNING**

**Personal Protective  
Equipment**

The products described in this publication may present risks that could lead to personal injury, loss of life, or property damage. Always wear the appropriate personal protective equipment (PPE) for the job at hand. Equipment that should be considered includes but is not limited to:

- Eye Protection
- Hearing Protection
- Hard Hat
- Gloves
- Safety Boots
- Respirator

Always read the proper Material Safety Data Sheet (MSDS) for any working fluid(s) and comply with recommended safety equipment.

### **WARNING**

**Start-up**

Be prepared to make an emergency shutdown when starting the engine, turbine, or other type of prime mover, to protect against runaway or overspeed with possible personal injury, loss of life, or property damage.

### **WARNING**

**Automotive  
Applications**

On- and off-highway Mobile Applications: Unless Woodward's control functions as the supervisory control, customer should install a system totally independent of the prime mover control system that monitors for supervisory control of engine (and takes appropriate action if supervisory control is lost) to protect against loss of engine control with possible personal injury, loss of life, or property damage.

**NOTICE**

To prevent damage to a control system that uses an alternator or battery-charging device, make sure the charging device is turned off before disconnecting the battery from the system.

**Battery Charging  
Device**

## Electrostatic Discharge Awareness

**NOTICE**

Electronic controls contain static-sensitive parts. Observe the following precautions to prevent damage to these parts:

**Electrostatic  
Precautions**

- Discharge body static before handling the control (with power to the control turned off, contact a grounded surface and maintain contact while handling the control).
- Avoid all plastic, vinyl, and Styrofoam (except antistatic versions) around printed circuit boards.
- Do not touch the components or conductors on a printed circuit board with your hands or with conductive devices.

To prevent damage to electronic components caused by improper handling, read and observe the precautions in Woodward manual **82715**, *Guide for Handling and Protection of Electronic Controls, Printed Circuit Boards, and Modules*.

Follow these precautions when working with or near the control.

1. Avoid the build-up of static electricity on your body by not wearing clothing made of synthetic materials. Wear cotton or cotton-blend materials as much as possible because these do not store static electric charges as much as synthetics.
2. Do not remove the printed circuit board (PCB) from the control cabinet unless absolutely necessary. If you must remove the PCB from the control cabinet, follow these precautions:
  - Do not touch any part of the PCB except the edges.
  - Do not touch the electrical conductors, the connectors, or the components with conductive devices or with your hands.
  - When replacing a PCB, keep the new PCB in the plastic antistatic protective bag it comes in until you are ready to install it. Immediately after removing the old PCB from the control cabinet, place it in the antistatic protective bag.





# Chapter 1.

## General Information

### Introduction

The 505CC-2 is a steam turbine and compressor control designed for use on a single- or two-valve steam turbine driving a one- or two-loop dynamic compressor. This manual, 26240, encompasses three separate volumes:

- Volume 1—Hardware and Installation
- Volume 2—Steam Turbine Control
- Volume 3—Compressor Control

This volume is dedicated to the compressor control, describing compressor I/O, operating point calculations, control functionality, and configuration and tuning procedures.

This manual does not contain instructions for the operation of the complete turbine and compressor systems. For turbine, compressor, or plant operating instructions, contact the plant-equipment manufacturer.

### Quick Start Guide

The following links provide shortcuts to pertinent information within this manual required of a typical installation. However, they are not intended to replace comprehensive understanding of the 505CC-2 and its functionality—***be sure to read and understand this manual fully.***

<b>Topic</b>	<b>Location (manual 26240)</b>
Physical Installation / Wiring	Volume 1, Chapters 2 and 3
Software / System Configuration	Volume 1, Chapter 3
Configuration File Management	Volume 1, Chapter 3
Modbus® *	Volume 1, Chapter 3
Security / Login Passwords	Volume 1, Appendix A
Turbine Configuration	Volume 2, Chapter 4
Turbine Operation	Volume 2, Chapter 5
Turbine Dynamics (PID) Tuning	Volume 2, Chapters 4 and 5
Compressor Configuration	Volume 3, Chapter 4
Compressor Operation	Volume 3, Chapter 5
Compressor Dynamics (PID) Tuning	Volume 3, Chapters 4 and 5

\*—Modbus is a trademark of Schneider Automation Inc.

# Chapter 2.

## Compressor Control Overview

### Introduction

The 505CC-2 is designed for compressor applications where protection and control are the primary concern. Typical applications include pipeline, utility (air, nitrogen, etc.), and chemical and refinery service. The 505CC-2 controls one or two recycle loops (or blow-off lines) on one- or two-section machines in a variety of physical configurations. Figure 2-1 shows a typical 2-section, 2-valve compressor train with an admission side-stream.

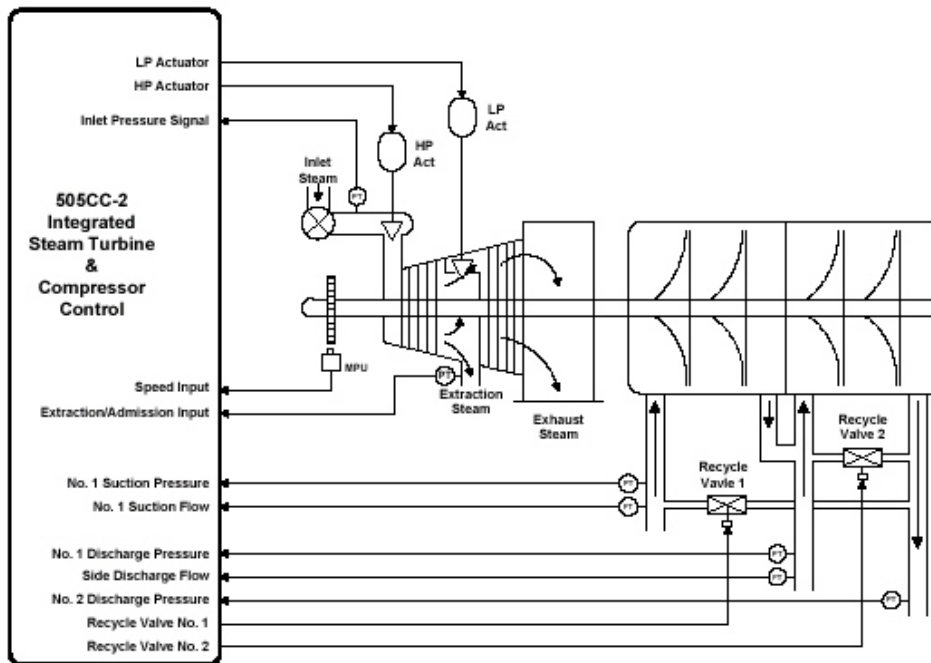

Figure 2-1. Typical Compressor Application

### What is Surge?

Since the fundamental purpose of any compressor control is to prevent or limit the effects of surge, it is appropriate to review the phenomenon itself. Surge occurs when the low flow operation limit of a compressor has been exceeded, resulting in flow reversal. It is an unstable, pulsating condition that is usually evident by an audible boom, piping vibration, rapid increase in discharge temperature and oscillation of flow and discharge pressure. Violent surging may cause the following compressor damage:

- Open internal clearances which damage impeller seals and balance piston seals.
- Damage the compressor shaft end seals.
- Damage to compressor thrust bearings.
- Damage to compressor radial bearings.
- Cause impellers to rub against stationary diaphragm.
- Cause a shaft coupling failure.
- Possible shearing of drive shaft.

Along with compressor damage, the process flow and pressure can become very unstable, contributing to upstream and downstream process upsets.

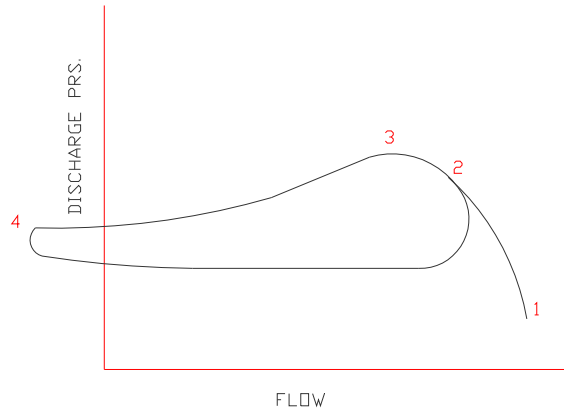

Figure 2-2. Surge Cycle

The illustration above shows a simple surge cycle at a constant speed and constant suction pressure. The compressor, operating at point 1, has low discharge pressure and the output flow is at its maximum value. As the system resistance increases (e.g. discharge valve closes, downstream processes shutdown or decrease load, series units drop off-line, or parallel units come on-line), the compressor flow decreases, and discharge pressure increases. At operating point 2, the compressor is near the surge limit. As the system resistance increases further, the flow continues to decrease, and discharge pressure continues to increase. Eventually, a limit is reached where the compressor can no longer increase discharge pressure, such as at operating point 3. If the system resistance increases further, the discharge pressure at the compressor becomes greater than the machine's capability. This initiates a surge that spans between points 3 and 4. Flow may actually reverse through the compressor, as shown at point 4. A now reduced system resistance will allow increased flow back through the compressor that brings the operation back to point 2. This surge cycle will continue until broken by some control or operator action.

Maintaining flow above the compressor's surge limit prevents these surge conditions. The controller must continually monitor the operating point and compare it to the surge limit of the compressor. If the operating point reaches a minimum flow value, the controller responds by opening the anti-surge valve(s). This simultaneously causes the flow to increase and polytropic head to decrease, moving the operating point away from the surge limit.

## Functional Overview

An overview of the 505CC-2 anti-surge and capacity control functions is shown in Figures 2-3 and 2-4. Use this diagram to match the 505CC-2's control features to the site-specific application.

**SIGNAL FLOW :**

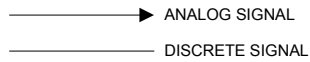

SIGNAL FLOW IS FROM LEFT TO RIGHT. ALL INPUTS ENTER FROM THE LEFT. ALL OUTPUTS EXIT TO THE RIGHT. EXCEPTIONS NOTED.

**CUSTOMER INPUT / OUTPUT :**

— — — 505ITCC BOUNDARY  
 INPUTS ORIGINATE ON THE LEFT SIDE OF THE DRAWING. OUTPUTS TERMINATE ON THE RIGHT SIDE OF THE DRAWING.

**INPUT / OUTPUT SYMBOLS :**

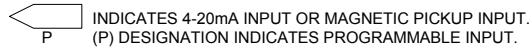
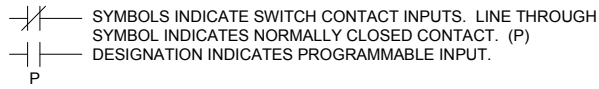

**FUNCTIONAL SYMBOLS :**

COMMON FUNCTIONS ARE REPRESENTED BY RECTANGULAR BLOCKS. A DESCRIPTION OF THE FUNCTION IS SHOWN INSIDE THE BLOCK.

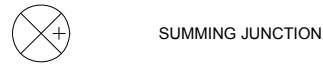
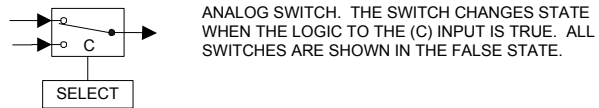
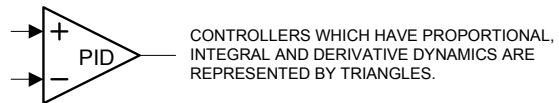
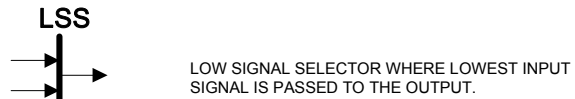
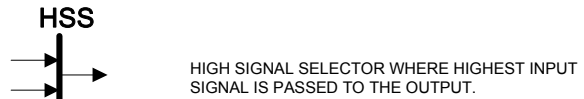
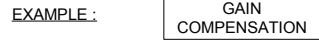

Figure 2-3. Overview of 505CC-2 Functionality Notes

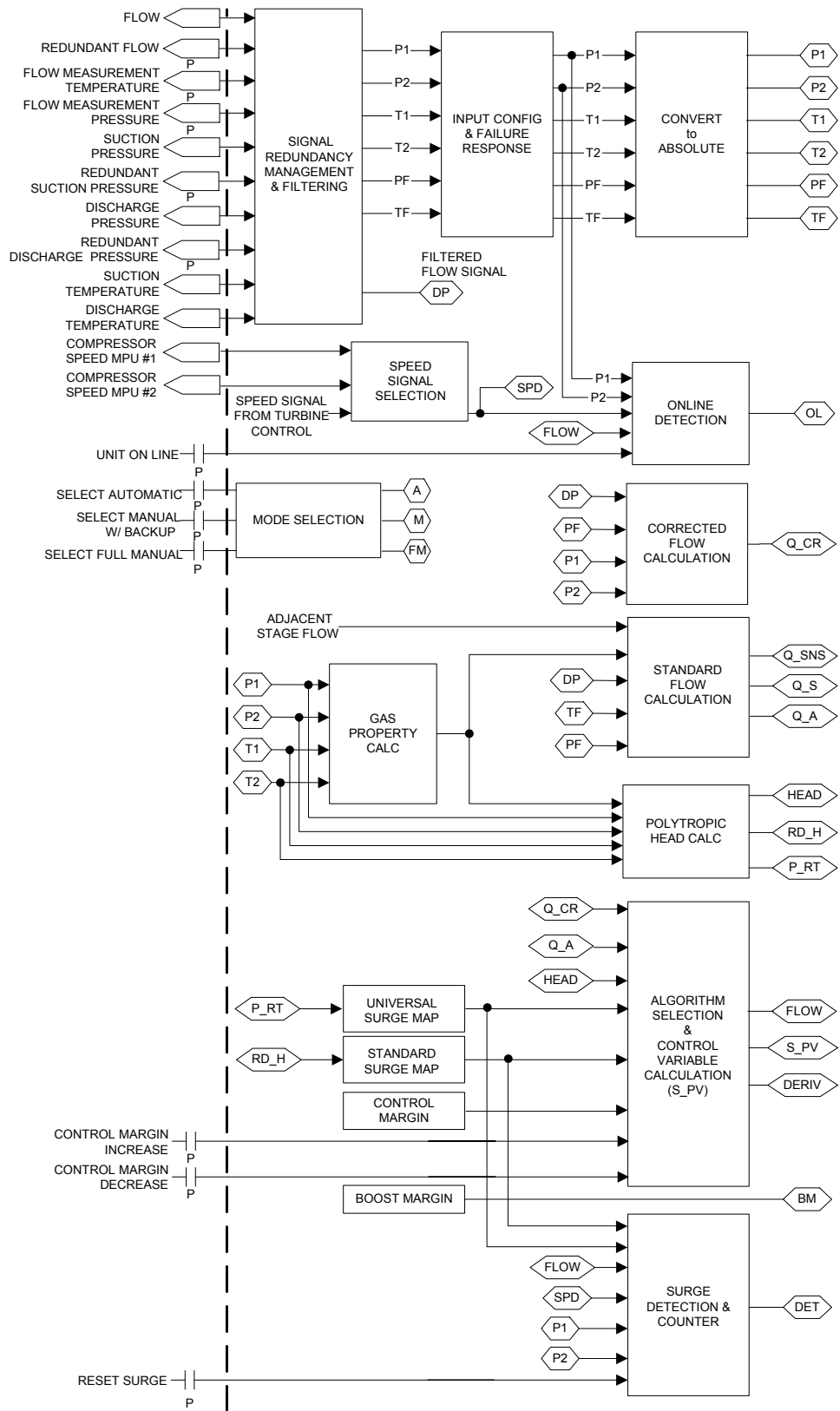

Figure 2-4a. Overview of 505CC-2 Anti-Surge Control Functionality

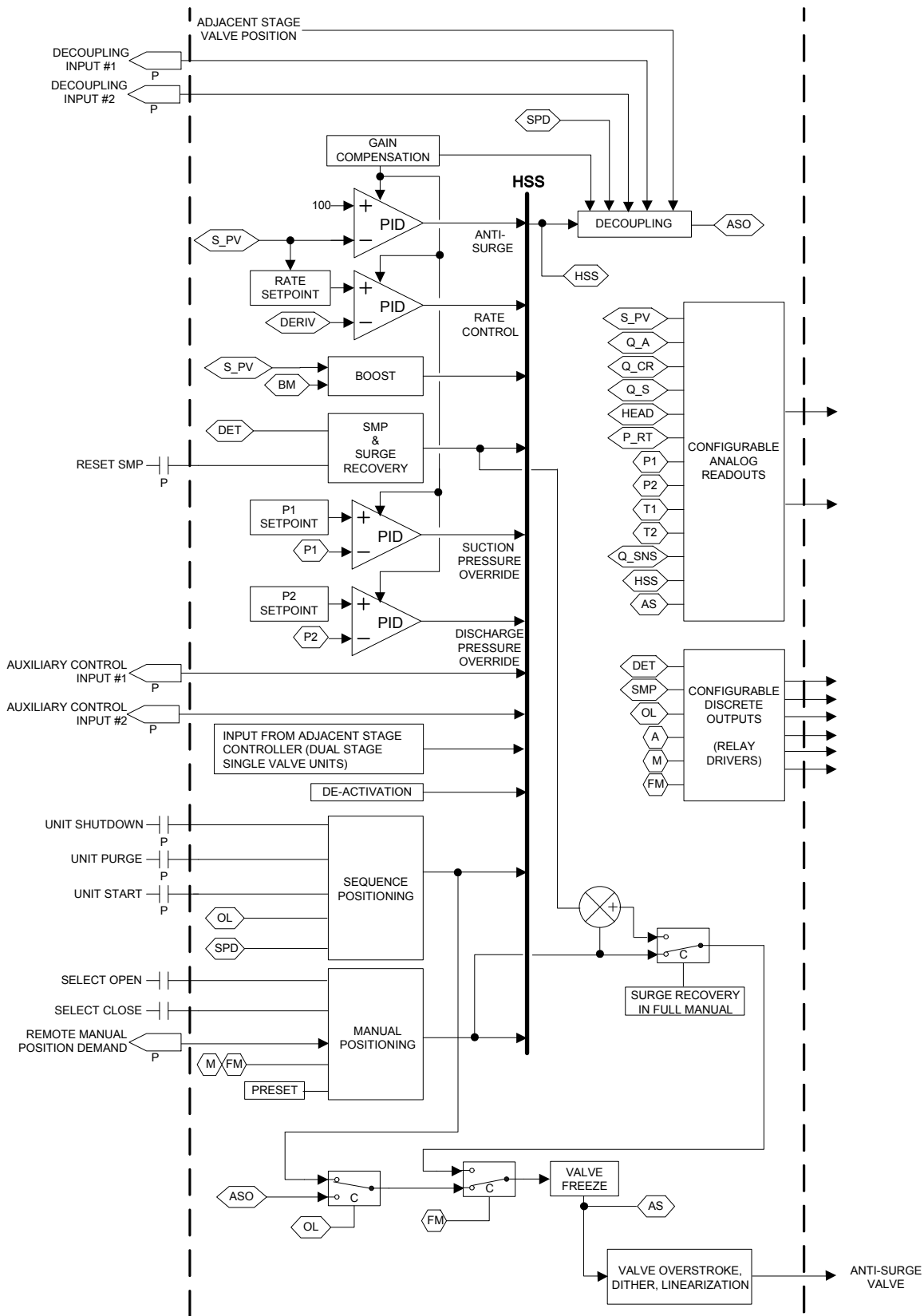

Figure 2-4b. Overview of 505CC-2 Anti-Surge Control Functionality

## Anti-Surge Control Theory

By modulating the anti-surge valve, the anti-surge controller maintains certain process conditions to:

- Prevent the compressor from operating in an unstable condition (surge or near surge), thereby preventing any surge related compressor damage
- Reduce process upsets
- Maximize the compressor and total train efficiency through utilization of control parameters
- Assist the station or total compressor process control strategy.

In order to perform these tasks, the controller must monitor the current operating point, generate a Surge Control Line (SCL), and compare the two to determine if movement of the anti-surge valve is necessary.

The compressor performance map describes the relationship between speed, pressures, temperatures, gas properties, and inlet flow. This map will also describe the operating limits of the compressor in terms of a Surge Limit Line (SLL) or surge region. Several variations are possible on how this information is presented, each describing the compressor with a different set of variables. The 505CC-2 accommodates two such compressor map definitions, Standard and Universal.

### Standard Compressor Performance Map

The Standard Compressor Map is described by polytropic head,  $H_p$ , versus actual volumetric suction flow,  $Q_a$ , and compressor speed,  $N$  (Figure 2-5). Depending upon the compressor configuration and instrumentation, changes in molecular weight, temperature, and compressibility are compensated for accurate representation of the compressor operation.

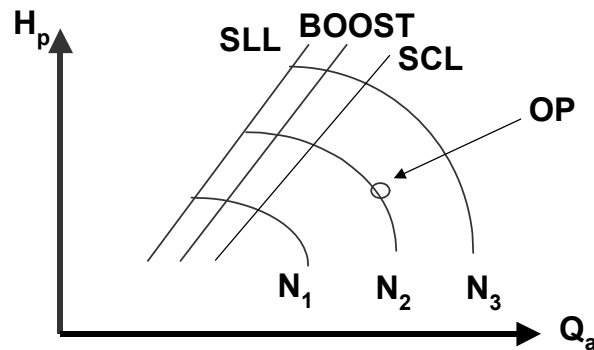

Figure 2-5. Standard Compressor Map

### Standard Operating Point

The definition of an operating point is necessary for any digital controller. It is easy for a person to identify the current operating parameters and relate these parameters to a surge control line on a compressor map. However, this is a difficult task for a controller to perform in varying process applications. Therefore it is necessary to define an operating point as a single number that can be handled easily. A further enhancement is to normalize this calculation for ease of understanding.

The Standard compressor map is presented in terms of polytropic head,  $H_p$ , versus volumetric inlet flow,  $Q_a$  (Figure 2-5). The operating point is also defined using these parameters. Simply, the operating point is defined as volumetric inlet flow squared divided by polytropic head.

$$\text{OperatingPoint} = \frac{(Q_A)^2}{H_P}$$

The result is a single number that identifies the operating point that can easily be manipulated by the controller and compared to a corresponding point on the Surge Control Line.

This calculation can be expanded to show that the operating point is invariant of the gas composition. All of the critical parameters in this equation can be measured, and the others can be estimated or assumed constant. A detailed explanation of the necessary equations can be found in the Operating Point Calculations section later in this chapter. For a simplified view of the measurements necessary to determine the operating point, refer to the process control diagram in Figure 2-6.

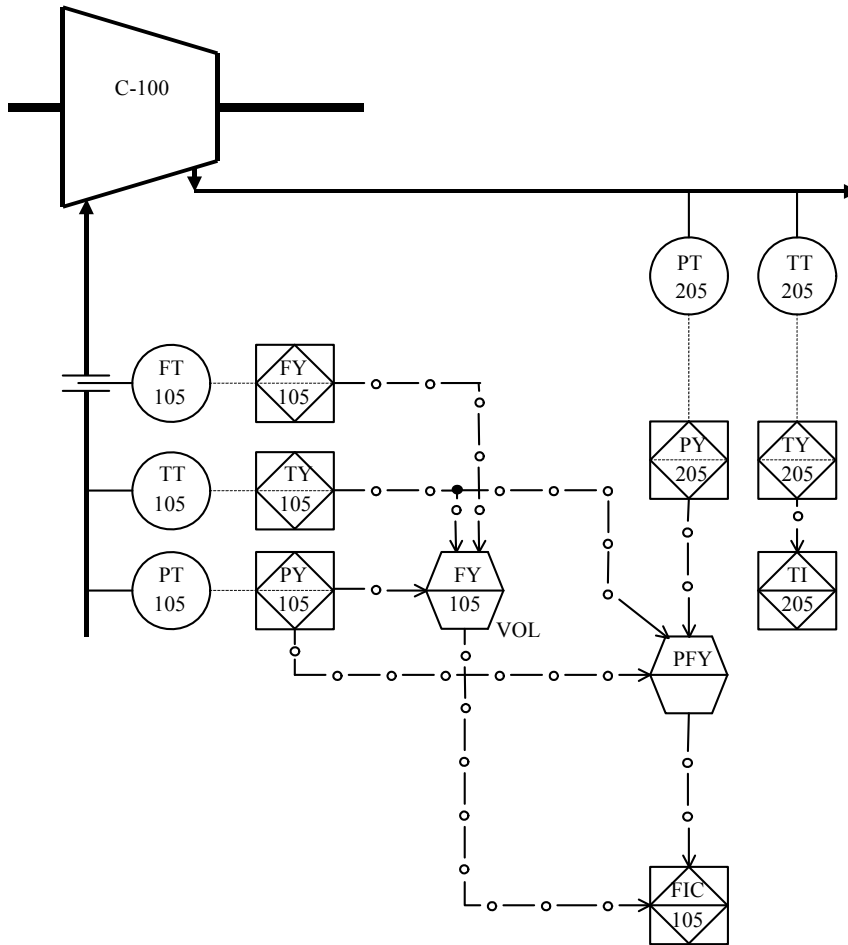

Figure 2-6. Process Control Diagram

Here it can be seen that the volumetric flow calculation is carried out using three measurements.

- PT-105, compressor suction pressure
- TT-105, compressor suction temperature
- FT-105, differential pressure across the flow element



The polytropic head calculation also requires three measurements.

- PT-105, compressor suction pressure
- PT-205, compressor discharge pressure
- TT-105, compressor suction temperature

If the gas composition through the compressor changes, the discharge temperature measurement, TT-205, would be necessary to calculate gas properties. This example assumes a suction flow element—Discharge flow elements are handled similarly.

## Standard Surge Control Line

Only a portion of the compressor map must be programmed into the anti-surge controller. Data points from the surge limit line are collected from the compressor map (Figure 2-5) and entered into the controller. Combining the surge line and a safety margin (user configured as a percentage of flow from surge) defines the Surge Control Line (SCL). This is the point at which the controller will limit operation by modulating the anti-surge valve.

The BOOST Line, or Backup Line, provides additional anti-surge protection. When the operating point (OP) reaches this line, a fixed response is triggered to prevent a surge. The BOOST Line is defined as a percentage of flow behind (to the left of) the Surge Control Line.

The Surge Limit Line is programmed into the controller as a series of operating points (five head-flow pairs). Occasionally, however, the given compressor map is not described in units of polytropic head and actual flow. In this case, the manufacturer's map must be converted to polytropic head and actual flow to enter the map into the control (The 505CC-2 Configuration Tool software will assist in this task). Additionally, surge limits are commonly unproven or unknown, so it is sometimes desirable to determine the values used for the surge points by field mapping the compressor.

It is recommended that all five pairs are different and entered successively lowest to highest. Compressors typically have higher flow requirements with higher head values.

## Universal Compressor Performance Map

While similar to the Standard Compressor Map, the Universal Compressor Map relates corrected suction flow,  $Q_{CR}$ , and pressure ratio,  $P_d/P_s$ , with compressor speed,  $N$ . This compressor map implementation, with the calculation of corrected flow, is invariant with process changes, such as molecular weight, pressure, temperature, and compressibility.

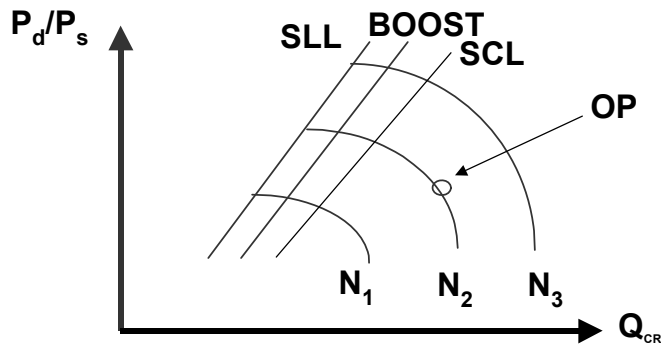

Figure 2-7. Universal Compressor Map

### Universal Operating Point

The Universal Compressor Map is in terms of pressure ratio,  $P_d/P_s$ , versus corrected inlet flow,  $Q_{CR}$  (Figure 2-7). Since corrected flow itself is invariant of the gas composition, the operating point is defined simply as the corrected flow.

$$\text{OperatingPoint} = Q_{CR}$$

The result is a single number that identifies the operating point and can easily be manipulated by the controller and compared to a corresponding operating point on the Surge Control Line.

The calculation of the corrected flow variable,  $Q_{CR}$ , is the key to the Universal Algorithm's immunity to process changes. It is related to mass flow ( $Q_M$ ) and more completely described as:

$$Q_{CR} = \frac{Q_M}{\rho \cdot \sqrt{RTZ}} = k \sqrt{\frac{h}{P}}$$

A detailed explanation of the necessary equations can be found in the Operating Point Calculations section later in this chapter. For a simplified view of the measurements necessary to determine the operating point, refer to the process control diagram in Figure 2-8.

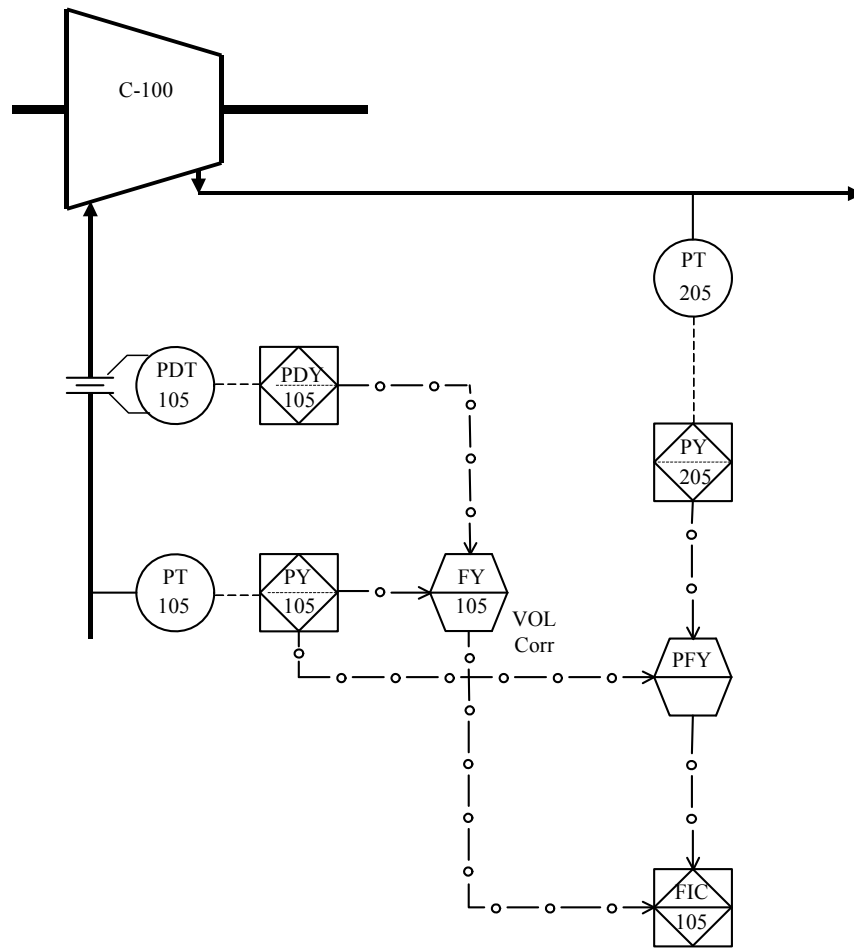

Figure 2-8. Process Control Diagram

Here it can be seen that the corrected volumetric flow calculation is carried out using only two measurements:

- PT-105, compressor suction pressure
- PDT-105, differential pressure across the flow element

The pressure ratio calculation also requires only two measurements:

- PT-105, compressor suction pressure
- PT-205, compressor discharge pressure

This example assumes a suction flow element—Discharge flow elements are handled similarly.

### Universal Surge Control Line

The first step in configuring the control for use of the Universal Algorithm is to convert the manufacturer's compressor map, specifically five Surge Limit Line pairs, into the  $Q_{CR}$  versus  $P_d/P_s$  representation (Figure 2-7). These data pairs are entered into the controller.

As with the Standard Algorithm, a safety margin (user configured as a percentage of flow from surge) and BOOST, or Valve Step margin (defined as a percentage of flow behind, or to the left of, the Surge Control Line) determine the points at which the controller will limit operation by modulating or stepping open the anti-surge valve.

## Standard or Universal Algorithm?

The decision of which algorithm to choose is largely subjective. The Standard Algorithm has been in use for compressor control for decades and is well accepted in the industry. The map is the same as that usually provided by the compressor manufacturer and is, thus, easily implemented. It also accepts any flow measurement input: linear, calibrated in mass or normal / standard volumetric units; or head-type, calibrated in flow element differential pressure with or without square root extraction. And, compensations are made for process changes in certain configurations.

The Universal Algorithm, one of several invariant coordinate systems, was developed as a more accurate predictor of compressor performance by eliminating any variances due to gas composition changes. Suction pressure, discharge pressure, and flow element differential pressure are the only measurements required, reducing instrumentation, cost, failure modes, etc. The corrected flow variable is calculated as a function of these measurements and a special corrected flow constant. This constant is calculated and input to the control during configuration and accounts for the method's immunity to gas composition changes.

The physical configuration of the compressor train occasionally dictates the use of one algorithm over another. See Appendix A and the 505CC-2 Configuration—Comp General section in Chapter 4 for supported compressor configurations.

## S\_PV (Surge Process Variable)

Regardless of the chosen map / algorithm, the anti-surge controller generates a single variable, S\_PV (Surge Process Variable), to describe the relationship between the current operating point and the corresponding point on the surge control line. This is done to provide the user and the control one number that reflects the current operating condition.

Once the actual operating point and the corresponding surge control line point are calculated, the ratio of these two parameters is calculated and then normalized to the value of 100 as shown below.

$$S\_PV = \frac{\text{operating\_point}}{\text{surge\_control\_line}} \cdot 100$$

By normalizing the process variable, each compressor section that is protected will control to the same number, 100. Notice that this is independent of the control margin that is programmed. In all cases, if S\_PV is equal to 100, the compressor is operating on the Surge Control Line.

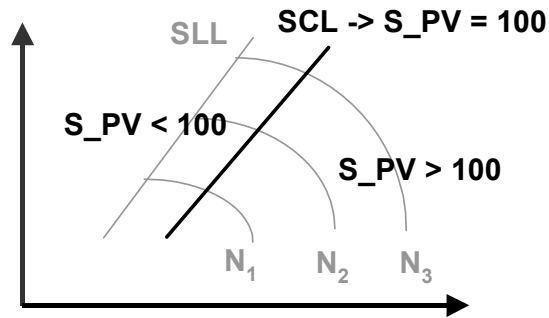

Figure 2-9. Compressor Map S\_PV Regions

A surge control margin is programmed by adding between 5%-25% to the flow values for the actual surge points, establishing a Surge Control Line. A typical surge control margin of 10% is attainable on most applications with proper anti-surge valve sizing, stroking speed, etc. However, if the anti-surge valve stroking speed or sizing is not optimal, the surge margin may need to be increased to insure protection of the compressor.

If S\_PV is greater than 100, the compressor is operating in a safe region of the compressor map. During this condition the anti-surge controller is able to close the anti-surge valve. When the value is equal to or less than 100, the anti-surge control will modulate the anti-surge valve to limit the operation of the compressor to be no further left than the Surge Control Line. Additionally, since compressor flow is proportional to speed, any speed reference lower commands in the turbine control are inhibited when compressor operation is on or near its control line. Failure to do so could inadvertently drive the compressor into surge by reducing flow.

To an operator, S\_PV is an indication of how far away the compressor is operating from the surge control line. Since the control set-point is always 100, regardless of the control margin, the operator can judge if the anti-surge valve will open when performing a process function. For example, a value of 180 indicates that the compressor is 80% of flow beyond the surge control line--The compressor is operating far from surge and the anti-surge system should close the anti-surge valve.

## 505CC-2 Anti-Surge Control Description

The anti-surge software provides all necessary functions from manual control to sequencing to closed loop PID control.

When the anti-surge control is in the Automatic mode or Manual with Backup mode, there are several controllers that can position the anti-surge valve. Each routine is an input into a high signal selector (HSS). The input with the highest value will control the anti-surge valve. These routines can be broken down into anti-surge control and process control routines.

In addition to compressor protection there are other supporting functions of the anti-surge control that reduce upsets, increase accuracy, and simplify programming.

## Control Modes

While on-line, the anti-surge controller is designed to operate in one of three control modes, Automatic, Manual with Backup, and Full Manual. These modes are provided to give the operator any level of control that is desired.

If the milliamp signal of the flow input is out of range (below 2 mA), an alarm will occur, the system reverts to Full Manual mode, and the anti-surge valve is positioned a configured percentage open. In this case, the Automatic and Manual w/ Backup modes will be inhibited until the input signal is corrected. If configured, a high-scale failure (above 22 mA) may alarm only—It is common for compressors to operate beyond the scale of a flow transmitter that is calibrated closer to surge limit flows. If desired, the same Fail to Full Manual response to a flow signal failure can be enabled for other inputs (pressures and temperatures).

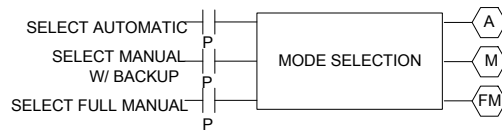

Figure 2-10. Mode Select

### Automatic

This is the strictest form of anti-surge control. There are no means for the operator to open or close the valve, except to change the process conditions.

The surge controller determines the operation of the anti-surge valve. The control monitors S\_PV and then determines the position of the anti-surge valve. While the control is in Automatic, the Manual mode will track the current valve position for a bump-less transfer to Manual, if performed. From Full Manual, the transfer back to Automatic is not bump-less if the automatic routines require a higher valve position.

### Manual with Backup

In this mode, the operator is allowed to open the anti-surge valve, but the valve may not be closed below the automatic demand. Effectively, the output to the anti-surge valve is the higher of the manual signal or the automatic signal.

The control still monitors the compressor operating parameters and the compressor map. If the control determines that the manual position demand will decrease the compressor flow below that of the surge control line, the automatic control will override the manual demand and open the anti-surge valve. Decoupling, if configured, is still active while in this mode.

### Full Manual

In this mode, the operator manually moves the anti-surge valve. The automatic controllers are bypassed and cannot operate the anti-surge valve, no matter where the operating point is on the compressor map. Decoupling is not active while in this mode. If enabled (recommended), "Surge Recovery in Full Manual" will allow the open-loop surge recovery routine to activate if a surge is detected when in Full Manual control. Full Manual is available in the Engineering or higher login level.

### Manual Valve Positioning

There are discrete inputs available for opening and closing the anti-surge valve when in Manual Mode. These inputs should be momentary, not sustained (toggles). When the input is closed, the valve is ramped at the configured "Manual Valve Rate." If the input is held for five seconds, the ramp speed will increase to three times that rate. A maintained contact will result in continuous change of valve position until the valve reaches its limits (fully open or fully closed).

Additionally, if an exact position is desired, a preset value can be entered and the valve will ramp to that position at the configured rate, described above.

Each of these positioning commands is disabled if Remote Positioning, described below, is active.

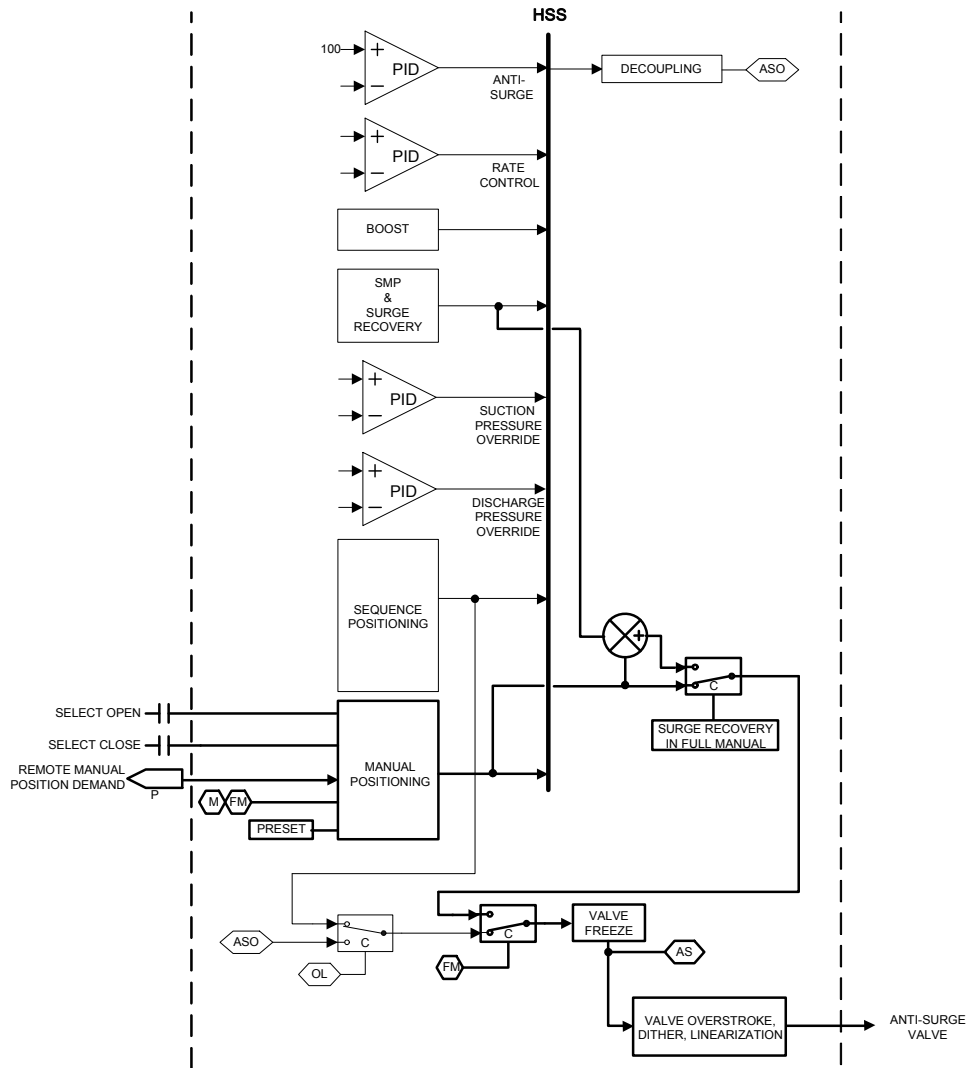

Figure 2-11. Manual Setting of Anti-surge Valve

### Remote Manual Valve Positioning

The Manual position can also be controlled via an analog signal. This allows an external control, such as a DCS (distributed control system) or other device, to position the anti-surge valve. The Remote Manual Valve Position's range is determined by the analog input's 4–20 mA range. While this range is configurable like any other analog input, it should not be set outside of 0 to 100%. "Remote Enable" must be selected in the compressor configuration.

If enabled, the Remote Manual Valve Position must match the current Manual position within 0.5% to permit remote control. Otherwise, remote positioning is inhibited. Once within 0.5%, the Remote Manual Valve Position will take over control. Regardless of the rate of change of the remote input, the valve will ramp at the configured "Auto Decay Valve Rate." Remote Manual Valve Positioning is automatically disabled on failure of the analog input or on any Fail to Manual condition (flow signal failure, etc.). Other Manual mode controls, such as the open/close discrete inputs and preset command, are disabled when remote positioning is active.

### Sequencing Functions

During start-up and shutdown of the compressor, the compressor flow is fluctuating, and the process is unstable. This time between a start and stable automatic control is termed "off-line." A separate routine is focused on detecting when automatic, or "on-line," operation is allowable.

To prevent the anti-surge controller from attempting any control function during the off-line period, sequencing provides fixed valve positioning. There are four programmable positions:

- Purge Position
- Start Position
- Shutdown Position
- Zero Speed Position

Speed set-points, discrete inputs, or combinations of both determine when to select the start, shutdown, and zero speed positions. The purge position can only be selected with a contact input or Modbus command.

### Sequencing

Using speed can simplify sequencing by allowing software speed switches to determine what state of start-up/shutdown the prime mover is in. Alternatively, discrete inputs or Modbus commands can signal a start or shutdown.

**START POSITION:** If speed is available, the start condition begins when speed exceeds the configured "Zero Speed Setpoint." The anti-surge valve is ramped from the "Zero Speed Position" to the configured "Start Position" at the "Manual Valve Rate." It will maintain this fixed position until the compressor is determined to be on-line. A momentary discrete input or Modbus command may also be used, but the software speed switch described here is always active. This start sequence is also reinitiated if any on-line trigger is deactivated while in normal operation.



**PURGE POSITION:** A purge sequence is required during the start-up of some processes to close the anti-surge valve, partly or fully, and send forward the process gas. During start-up, but before an “on-line” condition is triggered, a sustained discrete input or Modbus command will position the anti-surge valve in the configured “Purge Position.” The valve will remain in that position as long as the input is held and the unit remains off-line. At least one Online Detection method must be configured, but not yet satisfied, to allow a Purge cycle.

**ON-LINE:** Once all on-line triggers are satisfied (see below), the control will slowly close the anti-surge valve until the automatic anti-surge routines take control. If any on-line trigger is deactivated while in normal operation, the control returns to the start sequence.

**SHUTDOWN POSITION:** At any time, the compressor can be shutdown from the turbine software, from an ESD (Emergency Shutdown) or turbine trip for example, or by a discrete input or Modbus command. In any case, the anti-surge valve is immediately positioned and held at the configured “Shutdown Position.” If the shutdown condition is cleared (discrete input opened or Modbus command cleared), the unit can be restarted as described above.

**ZERO SPEED POSITION:** The anti-surge valve will remain in the shutdown position until the unit is re-started or the speed drops below the “Zero Speed Setpoint” for a configured “Shutdown Delay Time.” Once this delay timer expires, the anti-surge valve will be moved to the “Zero Speed Position.” This position can be useful in applications requiring the anti-surge valve be closed for process isolation after the compressor is shutdown. If the application does not require this final sequencing step, configure the Zero Speed Position to the same value as the Shutdown Position and the Zero Speed Delay Time to 0 seconds.

**On-Line Detection**

On-line detection is an important determination made by the anti-surge controller. Once the compressor is determined to be on-line, the surge detection and automatic control routines are activated. Suction pressure, discharge pressure, flow, speed, and an auxiliary input may be used together or independently to determine when the compressor is on-line.

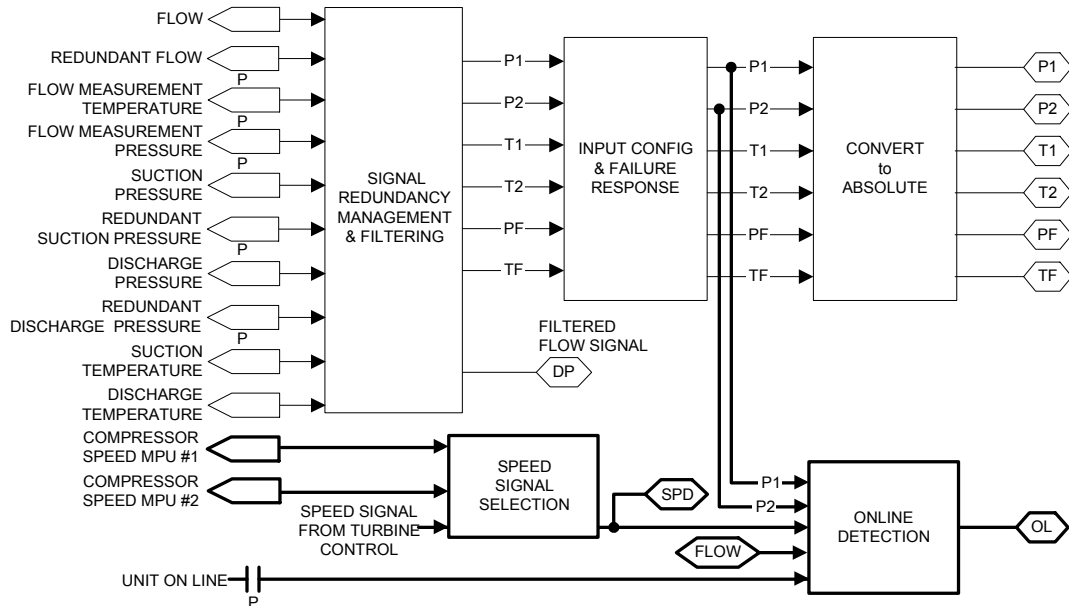

Figure 2-12. On-Line Detection

Each on-line detection method may be enabled or disabled and set-points configured in the Compressor Configuration section of the software. The Auxiliary Input (configurable discrete input or Modbus command), if enabled, must be a sustained input (toggle). It is often connected to a discharge check valve limit switch, for example. Speed, discharge pressure, and flow must exceed their respective set-points to signal the on-line condition. Conversely, suction pressure must drop below its set-point (Suction pressure of a second compressor section must exceed its setpoint, if enabled). If more than one method is enabled, all must be satisfied before the compressor is considered on-line. If none are enabled, the unit will transfer directly to automatic, online control during start-up—The anti-surge valve will not be held at its Start Position. This is usually undesirable as most compressors will be susceptible to surge during start-up. And, a Purge cycle, if requested, is not possible unless in a Start Sequence and prior to Online control.

## IMPORTANT

If utilized, the on-line contact input must be maintained closed the entire time the compressor is operating. If the contact is opened, the 505CC-2 will assume the compressor is off-line and revert to the start sequence and position the anti-surge valve at its start position.

Speed or the discrete input is the recommended, and usually the primary, on-line detection method. If other parameters are to be used, exercise care in selecting their set-points so as not to interfere with normal start-up procedures. Some start-up valve sequencing may inadvertently trigger the on-line status if set-points are configured too low (flow, discharge pressure).

## Anti-Surge Control Routines

Each anti-surge routine is designed to operate in a certain region of the compressor map. In total, these routines encompass the entire operating region (Figure 2-13).

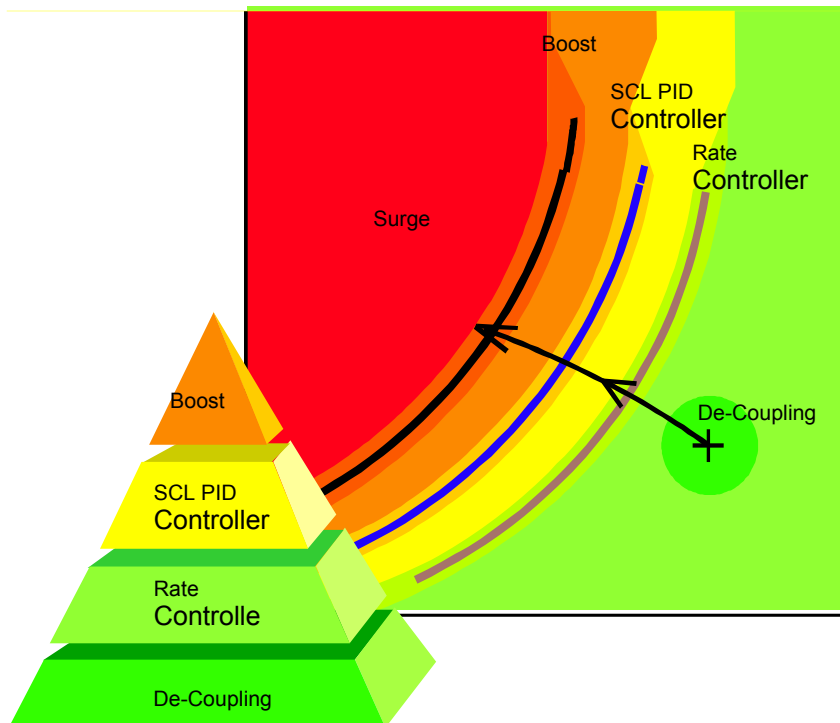

Figure 2-13. Anti-Surge Functions

Starting in the surge, or unstable operating region, there are three routines dedicated to preventing or responding to a surge. Surge Recovery and Surge Minimum Position (SMP) are the routines that react to a surge with a fixed (open loop) valve action. The amount of corrective action taken by these routines is not dynamic; it is pre-configured in the controller.

The next open loop function is BOOST, or Valve Step Opening. This routine monitors the operating point with respect to the BOOST, or Backup Line. If the operating point crosses the line it initiates a momentary, small, step increase in the anti-surge valve to prevent further movement toward the Surge Limit Line.

The two PID controllers are the main anti-surge protection routines. They monitor process conditions and provide a corrective action until the process returns to an acceptable operating point. These routines provide a continuous modulated output for the anti-surge valve. When the operating point is at the Surge Control Line (SCL), the Anti-Surge PID is active. If the operating point is away from the control line but approaching the SCL rapidly, the Rate Controller PID anticipates the need for action, opening the anti-surge valve earlier to slow the approach of the operating point.

Even when the operating point is not on the SCL decoupling acts to stabilize the process by minimizing the interaction of controllers.

### Surge Detection

The Surge Detection routines are configured to determine when a surge event has occurred, capture the surge signature, and maintain a surge counter. Refer to the What is Surge? section earlier in this chapter for further details of the actual surge event. The surge signature is a collection of values indicating how parameters change when a surge occurs. The routines available for surge detection are:

- Flow Derivative
- Suction Pressure Derivative
- Discharge Pressure Derivative
- Speed Derivative
- Minimum Flow
- Surge Limit Line Flow

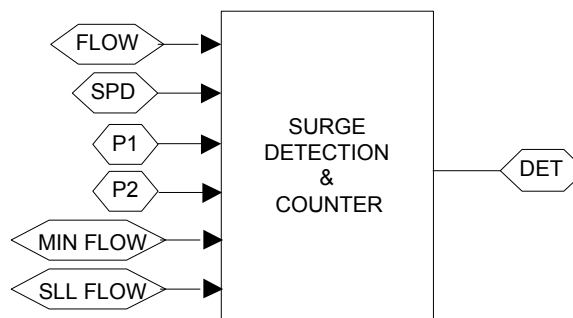

Figure 2-14. Surge Detection and Counter

Note that the latter two routines, Minimum Flow and Surge Limit Line Flow, do not actually detect a surge. They merely initiate a surge response if the calculated flow reaches the respective set-point.

These surge detection routines may be enabled as deemed appropriate and adjusted after the surge signature has been established (usually by recording data from a surge of the compressor). The most reliable detection routine is flow derivative. This routine is typically enabled before any surge data is available. The remaining routines are enabled as set-points are found during system tests. A detection routine should be enabled only if it is possible to discriminate a surge event from typical process upsets and signal noise.

The compressor must be on-line and the field sensors need to be operating to arm the detection routines. This prevents the surge control from falsely sensing a surge event during start up or when an input signal fails.

When the anti-surge control detects a surge, assuming surge detection and recovery functions have been configured, the following events will occur:

1. The surge counter will count the number of surges that were detected.
2. The anti-surge valve will open to the surge recovery amount.
3. The individual surge detection routines will capture the surge signature.
4. The individual surge detection routines will indicate which ones detected the surge.
5. An alarm will indicate that a surge was detected
6. The Surge Minimum Position (SMP) will be enabled.

### **Surge Counter**

The Surge Counter records the number of surges detected by the anti-surge controller. The counter increments one for each detection and is reset with the surge signature data. The Total Surges counter is also incremented, but it cannot be reset without special software maintenance tools.

### **Surge Recovery**

The anti-surge control cannot always prevent a surge from occurring. If the anti-surge routines do not prevent a surge, the surge recovery system takes over.

Once the controller detects a surge, Surge Recovery is programmed to open the anti-surge valve a fixed amount above the current position (see Figure 2-16). There is also a minimum amount that the valve must be opened to recover from the surge. The actual position will be the greater of the two values. The valve will remain open for the loop period time (see the Loop Period section) and then decay towards the closed position. This should stop the current surge cycle and allow the anti-surge routines to take control. Surge Recovery is inhibited when the unit is not on-line.

### **Surge Minimum Position (SMP)**

When the control detects that a surge event has occurred, the Surge Minimum Position (SMP) function will be activated. After the surge recovery routine breaks the surge cycle, the SMP routine will be enabled to prevent subsequent surges.

This routine captures the valve position when the compressor surges and then adds a small amount (SMP Amount) to that position. After the surge recovery decays to zero this routine will not allow the anti-surge valve to close beyond the SMP value (value at surge plus SMP Amount). Once process conditions are stabilized the operator can reset SMP and return to normal operation. This allows the operator to focus on the process if a surge occurs and return to the anti-surge control after the cause and/or a solution was found.

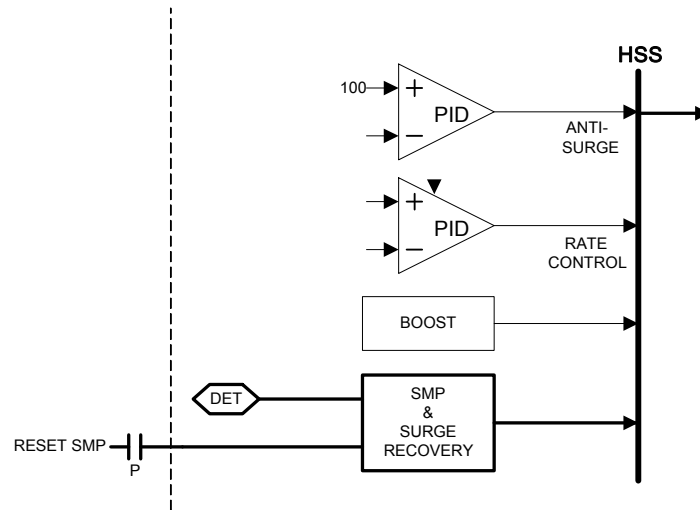

Figure 2-15. Surge Recovery and Surge Minimum Position (SMP)

For example, in Figure 2-16, the Anti-Surge PID and a single 3% BOOST response were not sufficient to prevent a surge, and the anti-surge valve was 34% open when a surge was detected. The SMP Amount was configured for 5%, generating an SMP value of 39%. The Surge Recovery Amount was configured for 14%, stroking the valve to 48% open to break the surge cycle. After the Loop Period duration, the Surge Recovery response ramped out. The anti-surge routines regained control but could not close the valve below 39%. The operator determined that a valve had inadvertently closed in the process and the problem was bypassed. Now, the operator can reset the SMP function that allows the anti-surge routines to close the valve further and move the operating point to the surge control line. As in any surge event, the cause of the surge needs to be investigated before resetting SMP. Resetting SMP may cause the compressor to surge again if the conditions that created the surge have not been corrected.

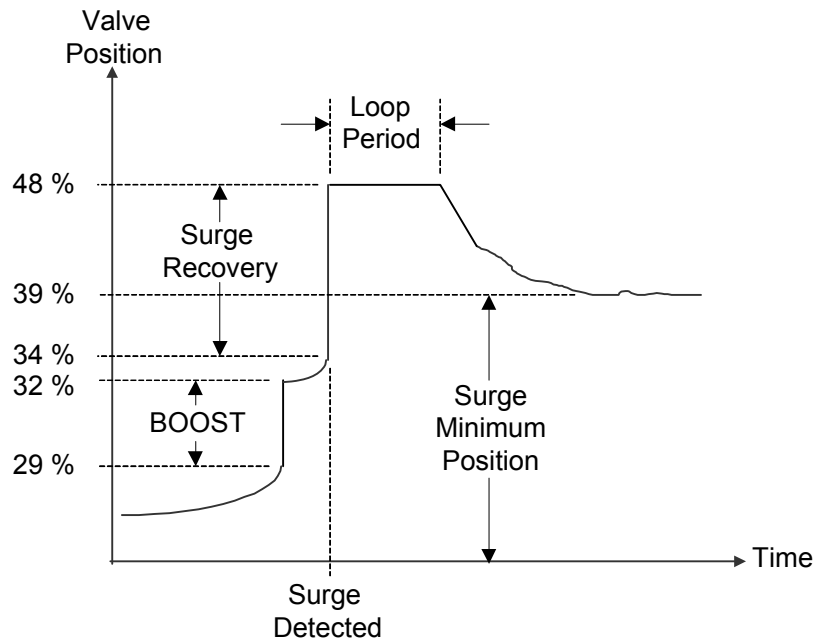

Figure 2-16. Anti-surge Valve Response to a Surge

### Boost / Valve Step Opening

The anti-surge control establishes a BOOST, or backup, line that is programmed between the Surge Limit Line and the Surge Control Line. If the anti-surge routines do not react fast enough, the operating point may cross the BOOST Line heading toward the Surge Limit Line. Once this occurs the BOOST, or Valve Step Opening routine will open the valve an additional amount and act to prevent a surge. The location of the BOOST Line is determined by the BOOST / Valve Step Margin, a percentage to the left of the Surge Control Line.

If the SCL margin is 15% and the Boost Margin is 5%, then the SCL is 15% from the SLL and the BOOST Line is 9.25% from the SLL ( $1.15 * 0.95$ ). The BOOST Line is always left of the SCL by the amount of the BOOST Margin. Hence, as the SCL moves so does the BOOST Line.

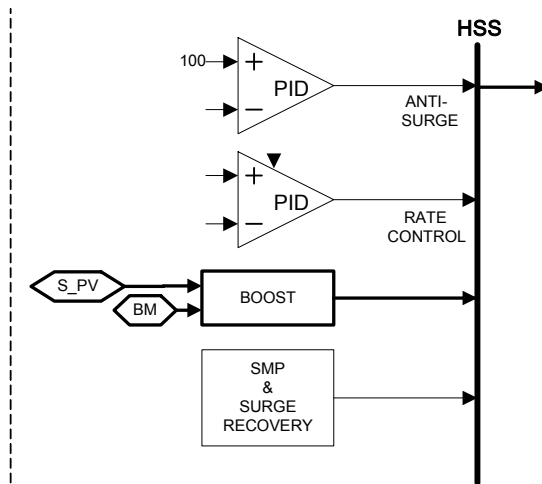

Figure 2-17. BOOST / Valve Step Opening

The BOOST action will open the anti-surge valve a configured amount above its current position. The valve will remain open this amount for a fixed amount of time (the loop period) and then check the operating point to determine if more action is required. If the operating point is above the BOOST Line, the BOOST action will begin to decrease and allow the anti-surge controllers to regain control. However, if the operating point is still below the BOOST Line, this sequence will repeat until the operating point is in a safe operating region of the compressor.

In normal circumstances, functioning as a safety net to the closed loop controls, this routine assists the Anti-Surge PID. The BOOST action is only a temporary event that is at zero output during steady state operation. It is inhibited when the unit is not on-line.

### Anti-Surge PID

This is the main anti-surge control routine. The Anti-Surge PID compares the process variable, S\_PV, to 100 in order to determine the proper position of the anti-surge valve. If S\_PV is greater than 100, the PID will move toward zero percent (closing the anti-surge valve). When the value is equal to or less than 100, the PID output will increase until the flow through the anti-surge valve restores S\_PV to the set-point of 100.

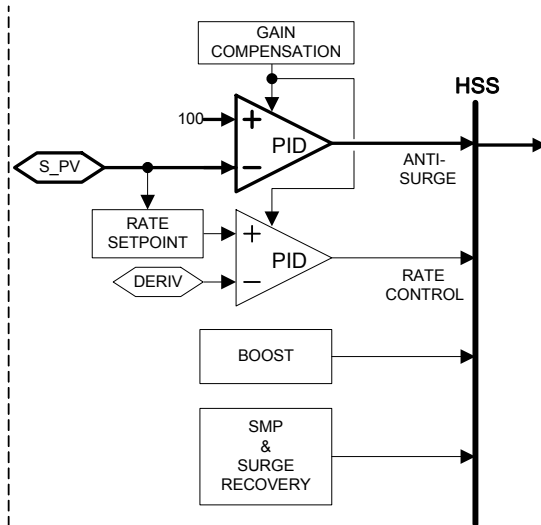

Figure 2-18. Anti-Surge PID

**Rate Controller PID**

If the flow through the compressor reduces too rapidly, the Anti-Surge PID may not react fast enough to prevent a surge. The rate controller monitors the time derivative of S\_PV and acts to open the anti-surge valve if this rate is too fast for the system to respond. This action will take place before the operating point reaches the Surge Control Line. It is a proactive routine that takes the place of derivative action in the Anti-Surge PID. The Rate PID is automatically disabled if any input signal is failed.

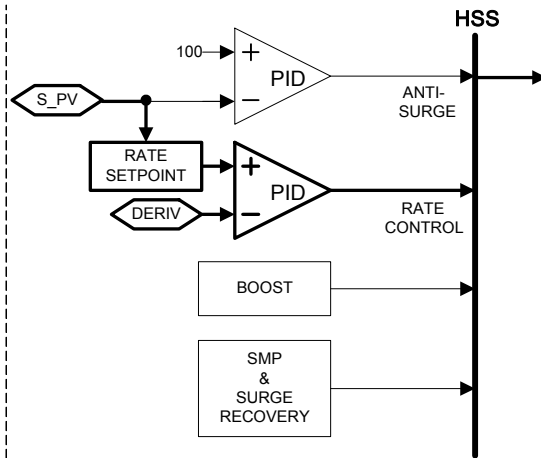

Figure 2-19. Rate Controller PID

The set-point for the Rate Controller PID is a percentage of the maximum safe rate of approach to the Surge Control Line. The allowable rate of approach to the SCL is dynamically calculated from the proximity to the SCL and the system response time (loop period), as shown below.

$$\frac{S\_PV - 100}{LoopPeriod}$$

The further the operating point is from the SCL ( $S_{PV} > 100$ ), the greater the allowable rate. Likewise, the faster the system can respond to changes (shorter Loop Period), the greater the allowable rate. As the operating point moves closer to the SCL, the rate set-point is reduced. This ensures that operation is not limited under normal conditions with the compressor loaded. As the operating point approaches the SCL it becomes more critical to limit the velocity of the operating point to maintain stability.

To ensure the controller has time to react, the actual rate set-point is a percentage, typically 60-80%, of this maximum allowed rate. Therefore, if the system dynamics require that the controller act sooner when the anti-surge valve is closing prior to reaching the SCL, reduce this Rate Setpoint. As this value approaches 100%, the Rate Controller set-point approaches the calculated maximum allowable rate.

**IMPORTANT**

**As Loop Period decreases, the maximum allowable  $S_{PV}$  rate increases, effectively “detuning” the Rate PID—It may not act fast enough for rapid operating point moves. For short Loop Periods, it may be necessary to decrease the Rate PID set-point. Obviously, system dynamics and tuning affect these values, so ample testing is key to determining the best settings.**

**Gain Compensation**

The Anti-Surge, Rate Controller, and Pressure Override PID dynamics include proportional, integral, and derivative action. These dynamics can be compensated by the Automatic Gain Compensation (AGC) routine as the compressor operating conditions change. This means that the PIDs can be tuned once during commissioning of the unit, and as the process conditions change, the PIDs will remain stable over the entire operating region. See the Dynamics Adjustments section in Chapter 4 for aid in tuning.

The gain compensation routine scales the proportional gains of all PID loops (Anti-Surge, Rate Control, Suction Pressure Override, and Discharge Pressure Override) as well as Fast Speed Decoupling, discussed later in this chapter. Gain compensation is calculated differently depending upon the choice of Algorithm. If the Standard Algorithm is utilized, the gain compensation routine constantly calculates full-open anti-surge valve flow under the current process conditions. The same calculation generates a “Normal Value” at the chosen operating point during initial commissioning and PID tuning. The resulting gain compensation value is the ratio of this fixed normal value to the current value that is constantly calculated. Hence, as compressor loading increases for a constant speed (higher flow, lower head), the calculated anti-surge valve flow will decrease. This increases the gain compensation value and results in more aggressive proportional gains, where gain compensation is applied. Without compensation, the overall control loop gain has been reduced since opening the anti-surge valve would divert relatively lower flow. Conversely, as compressor loading decreases (lower flow, higher head), the anti-surge valve flow calculation will lower the gain compensation value, detuning those proportional gains, since the valve gain has been increased by the process conditions.



Since the Universal Algorithm does not utilize temperature measurements and process parameters such as compressibility, valve flow cannot be calculated. Hence, a slightly different gain compensation routine is required. Standard condition valve flow (scfm, N·m<sup>3</sup>/hr) is highly correlated to the valve pressure drop ratio, or the compressor pressure ratio, which is measured. Actual flow at process conditions (Acfm, Am<sup>3</sup>/hr) will then vary with temperature and compressibility. Assuming compressibility near 1.0 that does not significantly change with process conditions, the latter can be ignored without introducing significant error, leaving only temperature as the unknown variable. Most compression processes can be characterized by relatively stable suction temperatures across the normal operating range. While this is not an absolute, it simplifies the gain compensation calculation to compressor pressure ratio instead of valve flow.

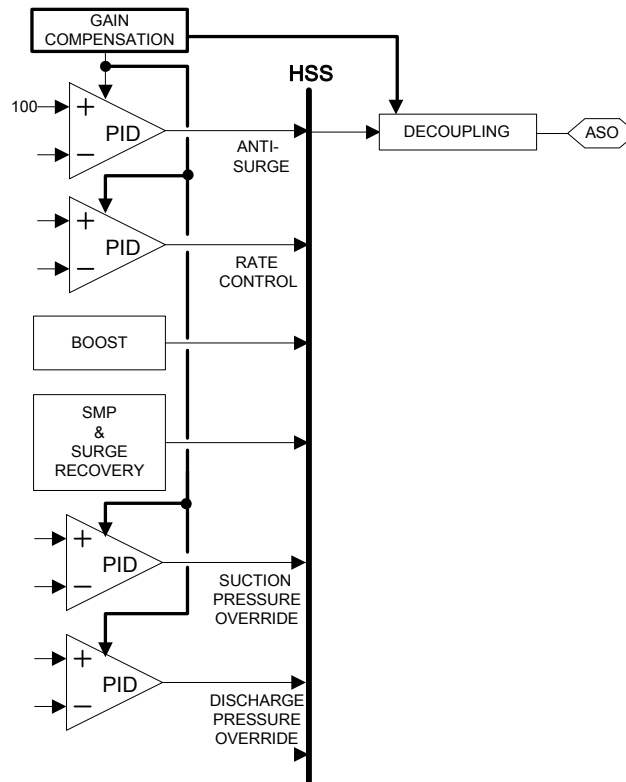

Figure 2-20. Automatic Gain Compensation

AGC must be configured if it is enabled on any of the four PID controls or if Decoupling is enabled and the “Fast Speed Amount” is not 0.0. That is, for Decoupling, Gain Compensation applies only to the Fast Speed routine. So, if that particular routine is disabled by tuning its amount to 0.0, AGC configuration is not necessary. The gain factor is automatically limited to a range of 0.2 to 5.0 within the control so as not to cause instability when applied to the PID gains. Gain Compensation is inhibited when any input signal is failed and when the unit is not on-line.

To configure AGC, first place the compressor in an operating condition where the operating point is above minimum head/flow conditions and below maximum head/flow conditions. Ideally this would be exactly in the middle of the compressor's map or near the normal operating point, although AGC can be tuned at any operating condition. The compressor must be on-line, and it is preferable to have the unit in Manual to prevent instability during this procedure. If the Standard Algorithm was selected previously, configure the anti-surge valve's full-open Cv value, which is required to calculate flow through the valve. The "Normal Value" is anti-surge valve flow (Am<sup>3</sup>/hr)—Tune this value until the "Gain Factor" equals 1.00. At this point, the "Normal Value" equals the flow through the anti-surge valve if it were 100% open at the current conditions. If the Universal Algorithm was selected previously, the "Normal Value" is compressor pressure ratio. As above, tune this value until the "Gain Factor" equals 1.00. At this point, the "Normal Value" equals the current compressor pressure ratio.

AGC is now configured at the current operating point. The gain factor will move above and below 1.0 as the compressor moves from this operating point.

## IMPORTANT

AGC may be configured before or after PID tuning, but in either case, PID loops should be tuned with AGC disabled. And, both PID tuning and AGC configuration should be done with the compressor at the same, or similar, operating conditions.

### Decoupling

In order to maintain a stable system, Decoupling may be necessary to provide action before an upset occurs. Upsets are anticipated from knowledge of the operating parameters and their relation to the operation of the anti-surge valve. For instance, a pressure set-point change will usually require a speed change, and this usually results in a compressor operating point change, in percent from the surge line. By the nature of changing speed, S\_PV changes and the Anti-Surge PID will respond. The decoupling routines are designed to anticipate the PID change and preset the anti-surge system to the final position without any PID action. Decoupling drives the system to stable operation much quicker than waiting for the PID output to settle. Additionally, the dynamics of the anti-surge control may be too close in response time to the pressure control/speed control and the two systems may fight. Decoupling will also drive this situation to a stable point.

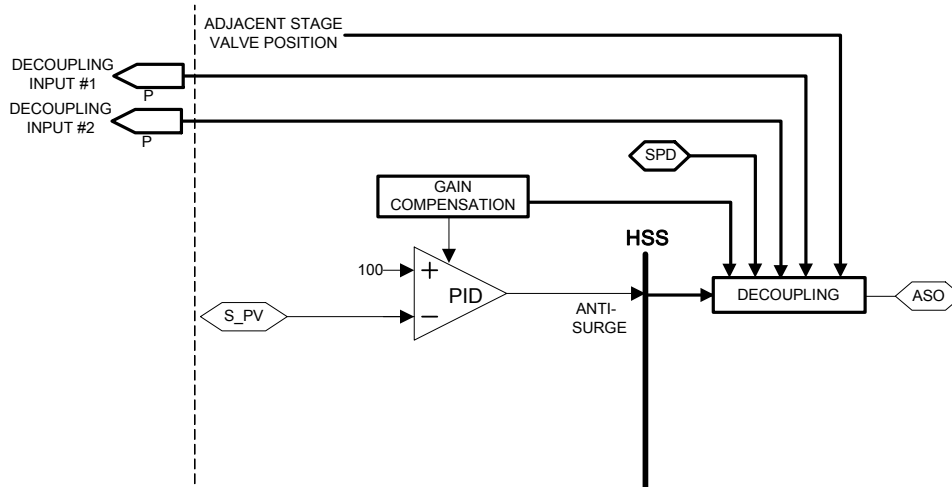

Figure 2-21. Anti-Surge Decoupling

There are five separate Decoupling routines: two based on speed, two configurable inputs from separate processes, and one based upon an adjacent compressor section's anti-surge valve. Decoupling is enabled as a whole—Disabling any of the five routines individually is done by configuring their respective “Amounts” to 0.0. In addition, the action is not allowed to influence the anti-surge valve until the compressor is on-line and in Automatic Mode. Also, since there is no need to manipulate the anti-surge valve if the compressor is operating far from the Surge Control Line, Decoupling is inhibited if the current S\_PV value is greater than the configured “S\_PV Range” value. And, since Decoupling is a supplemental function, not a primary control, its output is limited by the configured “Decoupling Output Limit”—The sum of all five decoupling responses may not open the valve more than this amount.

As mentioned previously, speed decoupling can be performed in two cases, one to prevent a surge and the other to stabilize the process. Once the compressor is stable at an operating point, a decrease in speed would move the operating point towards surge. The first form of speed decoupling uses a direct relationship from change in speed to generate the appropriate valve movement. This form is called “dynamic” and is fast acting and momentary. It is configured as the “Fast Speed Amount” in percent per rpm. Usually, the relationship of speed to S\_PV is direct so this value is set greater than zero. The time constant is configured as “Fast Speed Delay Time” and represents the total length of time that the decoupling action will last. The decoupling in this section is usually half or less the “Slow Speed Amount.” Gain Compensation impacts fast Speed Decoupling, so the decoupling should not be configured until after gain compensation has been configured.

The second form of speed decoupling uses knowledge of the relationship between speed and flow to anticipate the necessary movement of the anti-surge valve. The change in speed is related to a change in flow, and the anti-surge valve moves to maintain the previous flow. This type of decoupling is also quick to initiate, however, it lasts for a much longer period of time and is removed slowly. It is most helpful in load-sharing applications where there are several units piped in parallel or series. This slower acting decoupling is configured as “Slow Speed Amount” and is usually greater than zero. The time constant is set at “Slow Speed Delay Time.”

Field-testing is the only method to determine the relationship between a change in speed and a necessary change in valve position or flow. Both speed decoupling routines are disabled in the event of a speed signal failure.

Decoupling from an adjacent section anti-surge valve uses a direct relationship from a change in one valve position to generate the appropriate movement in another valve. Like all Decoupling routines, there is a filter component and an amount. However, piping arrangement, how one compressor's recycling affects flow through the other, must be considered when configuring the decoupling amount. Consider a two-section machine for which decoupling is configured for the first stage. If the second stage begins to recycle to the inter-stage piping, the system resistance to the first stage is increased, moving it towards surge. In this case, the “Another Stage Amount” would be a positive value. If, however, the second compressor section recycles to the first stage suction piping, the first stage flow would increase, moving away from surge. This situation would require a negative “Amount.” Similar relationships exist relative to decoupling the second compressor section from the first stage anti-surge valve. See Figure 2-22 for examples of Another Stage Decoupling values based upon piping arrangement.

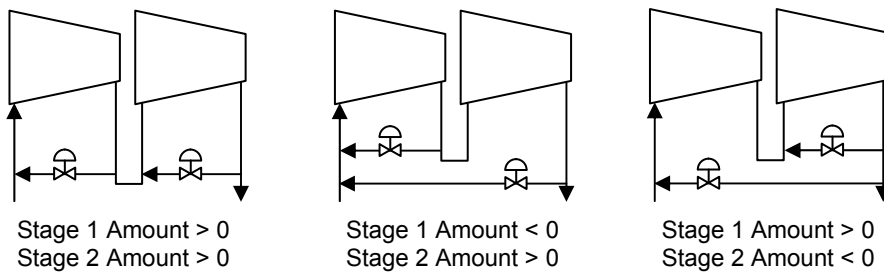

Figure 2-22. Effect of Valve Layout on Adjacent Stage Decoupling Amounts

Lastly, there are two configurable inputs of Decoupling. These inputs can be any other process variables that directly affect the flow through the anti-surge valve or the compressor. This form of decoupling relates a unit change in the process variable to a necessary change in the anti-surge valve position. Each decoupling input has a “Delay Time” and an “Amount” to configure (as with speed decoupling). As before, the larger the filter time constant, the longer the decoupling lasts before it is removed. The “Amount” value is the relationship of input change to decoupling output; a larger amount value translates into a higher impact of anti-surge valve movement to input change. And, like the Adjacent Stage Decoupling described above, the amount should be positive if the process variable is inversely proportional to compressor flow and negative if the relationship is directly proportional. These decoupling routines are disabled if their respective input signals fail.

## Process Control Routines

The following routines can operate the anti-surge valve to control a process condition other than anti-surge control. Contained within the 505CC-2 software are suction and discharge pressure controllers. When the prime mover’s speed is varied to maintain suction or discharge pressure, two problems can occur. First, the response to a change in speed and a change in pressure may be too slow. Second, if the prime mover’s minimum speed is reached, suction or discharge pressure cannot be maintained at their respective set-points. In these cases, this controller will modulate the anti-surge valve to control pressure and assist the primary controller. Both Suction Pressure Override and Discharge Pressure Override may be simultaneously activated. Both may also utilize Automatic Gain Compensation, described previously. Each is automatically disabled if its respective input signal fails.

In the case of 2-loop compressors, the recycle piping arrangement can affect the implementation of these override controllers. Consider a dual stage, 2-valve compressor with a common suction, or “Stage + Overall,” valve configuration. In this scenario, opening either valve will boost the unit suction pressure; opening the Stage 1 valve will relieve interstage pressure; and opening the Stage 2 valve will relieve unit discharge pressure. There is no override routine for Stage 2 suction pressure—The Stage 2 Suction Pressure Override controller acts on the unit suction pressure, not the interstage pressure. Since both Suction Overrides act on the same process variable, only one should be enabled, or their setpoints staggered to prevent interaction if both are enabled. Similar caution should be applied to common discharge piping arrangements.

Since the pressure override controllers are high signal selected with all other anti-surge control routines, their effect may be negated if normal compressor operation is on the control line. In this case, the Anti-Surge controller will already be modulating the valve at some open position. If an override controller begins to act, it must exceed the demand of the Anti-Surge PID in order to increase the current valve position. This probably will not occur unless the override controller tuning is very aggressive (undesirable) or the valve is open only a small amount. As such, enabling and tuning the override controllers may be helpful only when the compressor is loaded sufficiently for the Anti-Surge PID to keep the valve closed, or nearly closed.

To allow external control of the anti-surge valve, two auxiliary inputs to the HSS are also available. These inputs will position the compressor anti-surge valve based upon demands from external devices, but all automatic routines within the 505CC-2 are still active. The HSS will select the highest valve position regardless of its control source.

### Suction Pressure Override

The Suction Pressure Override routine monitors the difference between the suction pressure set-point and the compressor suction pressure. If enabled, the override controller will open the valve to help boost the suction pressure as needed. Obviously, the anti-surge valve cannot be used to reduce suction pressure, in which case the prime mover's speed controller, or other control loop, acts alone.

### Discharge Pressure Override

The Discharge Pressure Override routine monitors the difference between the compressor discharge pressure and the discharge pressure set-point. The override controller will open the valve to help reduce the discharge pressure. Obviously, the anti-surge valve cannot be used to increase discharge pressure, in which case the prime mover's speed controller, or other control loop, acts alone.

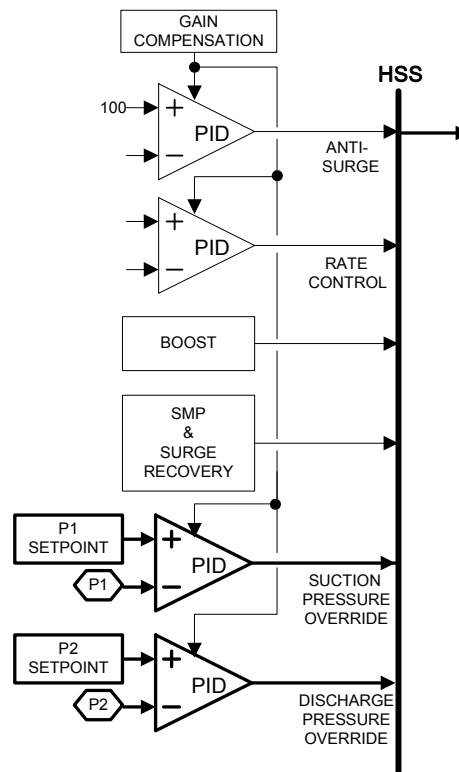

Figure 2-23. Pressure Override Control

## Auxiliary Control

One or two custom controllers may be added to the High Signal Select (HSS) bus within the 505CC-2. These are configurable analog inputs that must be calibrated for 0-100% open on the anti-surge valve. Enable use of these “HSS Aux #1” and “HSS Aux #2” inputs on the I/O Configuration screen. If necessary, a first-order lag filter delay time may also be configured. If either input signal fails, it is ignored by the HSS.

A third such auxiliary HSS input is used internally when a two-section compressor train is protected with a single anti-surge valve. The single anti-surge valve is driven from the first-stage controller. The second-stage controller’s valve output provides a signal to the first controller’s HSS bus. To provide tracking, the first controller supplies a valve output signal to the second controller’s HSS bus. Connected such, either compressor section’s anti-surge control may position the single anti-surge valve depending on their individual operating points.

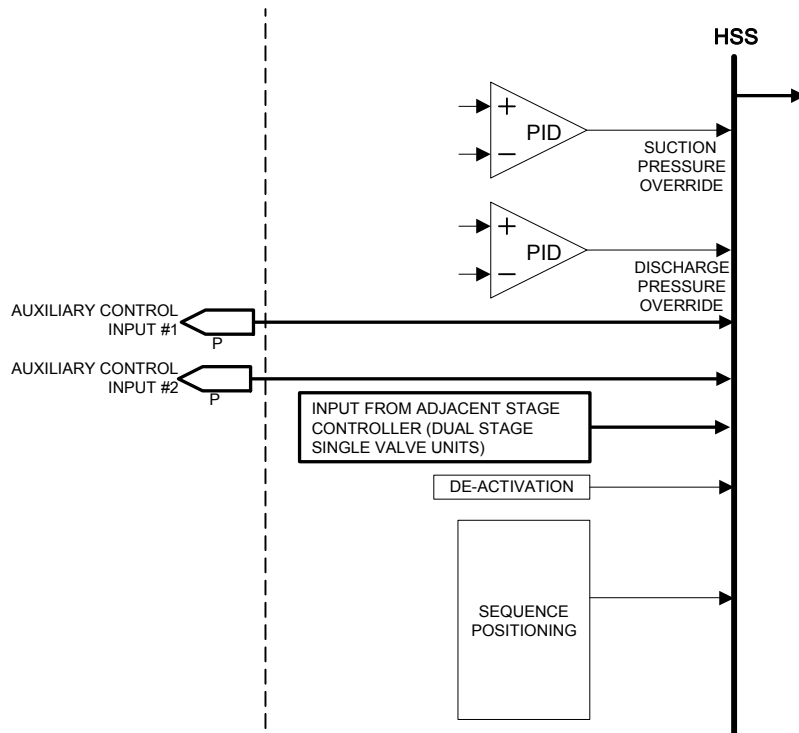

Figure 2-24. Auxiliary Control Variables

## Support Functions

In addition to anti-surge control routines, there are support functions that enhance the 505CC-2’s abilities:

- Configurable analog inputs may be used for redundant flow and pressure transmitters.
- Input signals are filtered and monitored for failures that trigger fallback routines.
- The Surge Control Margin may be automatically increased, to provide more conservative control, when surges are detected.
- Freeze, over-stroke, dither, and characterization functions provide customization of the anti-surge valve output signal.
- When system response time (loop period) is excessive, Pre-Pack may be used to decrease system reaction time.

- Deactivation logic provides bumpless transfer between the various control routines.
- Gas properties are calculated for greater accuracy (Standard Algorithm).
- A high-speed datalogging function is provided.

### Signal Redundancy

While the 505CC-2 hardware platform does not incorporate true fault tolerance, redundant field instruments (flow, suction pressure, discharge pressure) can be assigned to the available configurable analog inputs to provide some protection against typical transmitter failures. There are only five configurable compressor inputs, so redundancy will be limited for a two-section compressor. The redundancy management and signal selection occurs before filtering.

Range and failure set-point calculations are made from the primary transmitters' configurations, so it is strongly advised that redundant transmitters have the same calibration ranges as their respective primary transmitters. Any single input that fails (outside the default 2–22 mA window) will generate an alarm, but the control will continue to operate on the good signal.

A gradual deviation between the two signals will force the control to choose a “good” value from the two. This situation will generate a Max Difference alarm if the deviation exceeds 1% of range. Since there is no way to predict which of the two, if either, is the “good” signal, the control will select the most conservative value for control—that which will produce the lower S\_PV calculation:

- Compressor 1 Flow – LSS (Low Signal Select)
- Compressor 1 Suction Pressure – HSS (High Signal Select)
- Compressor 1 Discharge Pressure – LSS (Low Signal Select)
- Compressor 2 Flow – LSS (Low Signal Select)
- Compressor 2 Suction Pressure – HSS (High Signal Select)
- Compressor 2 Discharge Pressure – HSS (High Signal Select)

Each of these choices (HSS or LSS) might be different for different flow element locations, sidestream direction (if applicable), and algorithm (Standard or Universal). For example, Stage 1 suction flow is directly proportional to the Stage 1 Flow input in all cases, except when the flow element is located in an admission sidestream. In this latter configuration, choosing the higher of two flow input signals would result in a lower calculated suction flow (Stage 1 Flow = Stage 2 Flow – Admission Flow). However, the selection of high or low input is fixed—The software cannot change between HSS and LSS. Therefore, the most common applications were used to establish the high/low select method, even though it may not produce the desired effect in absolutely every configuration. In any case, when using redundant inputs for flow and/or pressure and a Max Difference alarm occurs, it is strongly recommended that the compressor operation be carefully monitored and the faulty input signal identified and corrected as quickly as possible,

Failure of both inputs will revert to the failure routines described below.

### Signal Filtering

All of the signals that are input into the anti-surge controller may be filtered for noise. This aids in preventing false surge detections, prevents unnecessary response to noise, and stabilizes the control routines. All input signals are filtered after scaling and redundancy management. If process measurements are clean enough to provide adequate control without filtering, configuring filter time constants of 0 seconds would optimize the controller's speed of response. In any case, if filtering is deemed necessary, it is recommended to enable it in the control, not in the field device—Disable or minimize any transmitter filtering.



Temperature and pressure measurements can be filtered with a high level of accuracy due to the expected responsiveness of these process signals. The filter is a simple first-order lag. The lag time constant, in seconds, is configured on the Stage I/O Configuration Screen. Since it is a time constant, a high value is required if the noise is of low frequency or high amplitude. Typical defaults are 3.0 seconds for temperature inputs and 0.2 seconds for pressure signals.

In contrast, the flow sensor requires careful consideration as it is typically noisy but is the primary surge detection signature. As a result, the anti-surge controller employs a more elaborate filtering scheme. A simplified ARMA (Auto-Regressive Moving Average) filter provides a highly correlated signal without excessive delay times. A lag time constant is configured similarly to the other inputs but is used in a fourth-order filter scheme that weights the lagged signals according to their respective “ages.” The most recent value is given the largest weighting, while the “oldest” value has the lowest weighting. Flow signals require much faster filtering than do pressures and temperatures. Lag time constants are typically less than 100 milliseconds.

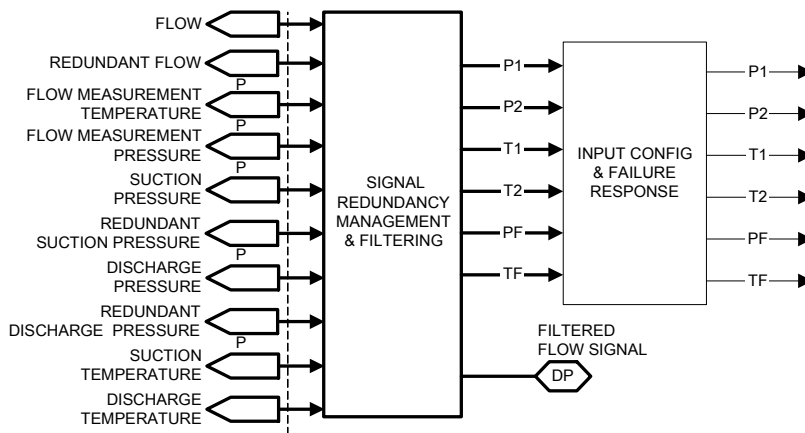

Figure 2-25. Analog 4–20 mA Input Signal Filtering and Failure Monitoring

### Surge Control Line Shifting / Control Margin Bias

Occasionally, changing process conditions will move a compressor’s normal operation toward its surge limit. Consider an aging compressor in a dirty gas service. Internal fouling may reduce the compressor’s efficiency, reducing flow output at a given head. These situations may eventually deteriorate into frequent but unnecessary surge events because of compressor mechanical conditions or process conditions changing over time. As a result, it may be necessary to increase the control margin to account for this deteriorating controllability.

The 505CC-2 offers automatic biasing of the control margin to shift the Surge Control Line when surges are detected. This feature is a temporary solution to a surge event. If enabled, the control margin will shift to the right a configured amount for each surge detected, as enumerated by the surge counter. For example, if the control margin is at 10% and a surge event records 3 individual surges, a configured SCL Shift Amount of 1% would bias the control margin to 13% from 10%, or 1% for every surge detected. When the surge counter is reset, the shift amount ramps slowly back to 0, gradually returning the SCL to its original location determined by the configured base control margin. If the process change that initiated the surge event is deemed chronic, as in the fouling example noted above, the base control margin should be increased to permanently move the SCL.



This biasing would normally be used only if the compressor's normal operation is at or near the Surge Control Line and the unit is susceptible to intermittent but significant process disturbances that can lead to surge.

### Signal Failure Routines

When a field sensor (or both sensors, if redundant) used for surge protection fails, three automatic actions are possible. The first action, if enabled, verifies steady state operation and uses the last good process value (LGV) for that signal before the sensor failed. This action is inhibited if the compressor operation was not stable prior to the failure, rendering the validity of "last good value" questionable. LGV can be enabled or disabled for individual inputs.

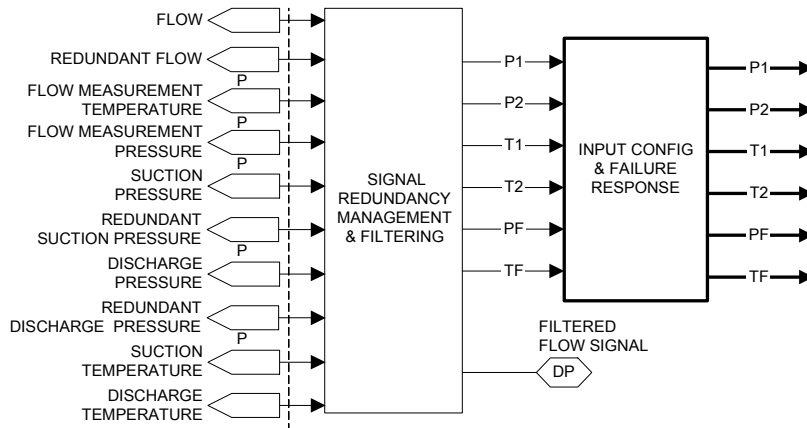

Figure 2-26. Input Signal Configure and Failure Response

Operational stability is determined by monitoring speed, flow, suction pressure, and discharge pressure. If each input is stable for approximately one minute, the compressor is in a steady state condition, and the last good value selections, 30 seconds previous, would be valid. If the compressor were to move from this operating point, at least two of these four inputs will change, indicating an unstable operating condition and inhibiting last good value selection. Movement of the compressor operating point requires that at least two inputs are changing. Therefore, if only one input moves from the stable condition, it may be an indication of a failing signal while the actual compressor operation remains stable. In this case, last good value remains enabled.

### IMPORTANT

Last Good Value monitors for approximately one minute of stable operation and selects the value from 30 seconds prior to the failure. Failure is defined as an input signal that moves outside of the normal 2–22 mA (or other) operating range. If a transmitter is failing slowly, or drifting, and the signal takes longer than 30 seconds to reach the milliamp limits, the LGV routine may select an inappropriate value.

The second action is taken if the system steady state condition changes or a second signal failure occurs while using the last good value for any input. In this case, or if LGV is not enabled, the control value for that input is transferred to a configured fail-safe default. At the moment any signal failure occurs, the values of speed, flow, suction pressure, and discharge pressure are captured. If the current values of these sensors change (one percent for pressure, three percent for flow, one percent of minimum governor for speed), or if a second sensor fails, the system can no longer be considered steady state. At that point, the last good value, if it is being used, is discarded and the control will transfer to the constant fail-safe value. These default values should be chosen to generate a conservative S\_PV.

The third signal failure routine is to switch to Manual control and step open the anti-surge valve on any signal failure. This is a single strategy that is enabled or disabled for all inputs. The Last Good Value and Default Value routines will allow the compressor to run uninterrupted, thereby eliminating unnecessary recycling because of a transmitter failure. But, predicting the actual compressor operating point is somewhat compromised. Fail to Manual is the most conservative reaction, opening the anti-surge valve a configured amount beyond the current position to ultimately protect the machine when important process data is unavailable.

This Fail to Manual scheme is the only available routine if the flow sensor fails-- The system does not have the capability of using the last good value or a default value for flow. Without the flow signal, the operating point of the compressor cannot be determined, which makes it impossible to automatically control the anti-surge valve.

While a flow signal failure has but one backup routine, there are several possible response sequences to other signal failures, depending upon compressor operational stability and the configuration of Last Good Value and Fail to Manual. See the chart in Figure 2-27, for the order of events after an initial signal failure and subsequent operational instability.

Signal	LGV Enabled?	Fail to Manual Enabled?	Operation Stable?	1st Response to Initial Signal Failure	2nd Response to Steady State Failure
Flow	N/A	N/A	N/A	Fail to Manual	N/A
Others	Enabled	Disabled	Stable	LGV	Default Value
	Enabled	Disabled	Unstable	Default Value	N/A
	Enabled	Enabled	Stable	LGV	Fail to Manual
	Enabled	Enabled	Unstable	Fail to Manual	N/A
	Disabled	Disabled	Stable	Default Value	N/A
	Disabled	Disabled	Unstable	Default Value	N/A
	Disabled	Enabled	Stable	Fail to Manual	N/A
	Disabled	Enabled	Unstable	Fail to Manual	N/A

Table 2-1. Input Signal Failure Response Sequences

### Valve Freeze Mode

Under some operating conditions the anti-surge control will constantly modulate the anti-surge valve to some partially open position. The nature of PID action is to open and close a valve to eventually eliminate any error between set-point and process. If the routines are constantly and perhaps unnecessarily moving the valve, the Freeze Mode will hold the valve position until the process changes. This can prevent unnecessary wear in the anti-surge valve and help stabilize minor process swings.

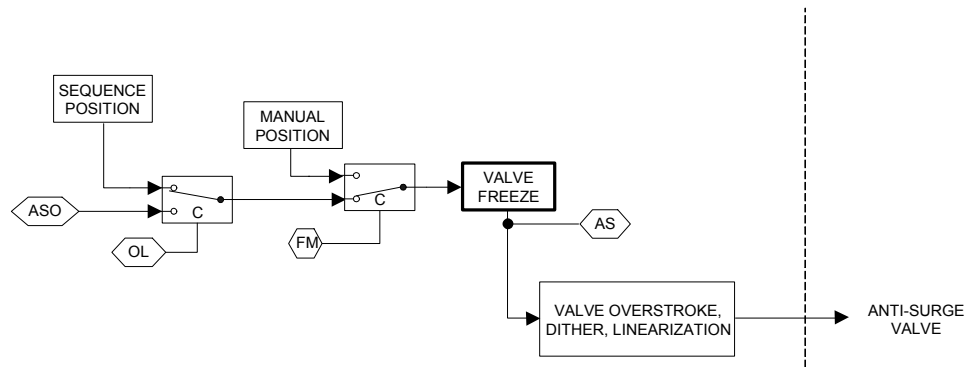

Figure 2-27. Valve Position Freeze Routine

The “Freeze Delay Time” defines the time interval at which the Freeze function is enabled, or sampled. In other words, after that time delay, the Freeze routine is initiated. However, to determine if the valve movement should be stopped, two criteria must be met. First, the valve position must be moving less than two percent (peak-to-peak). Second,  $S\_PV$  must stay within a window of six percent (peak-to-peak). If both of these conditions are satisfied, the valve demand will remain clamped by the Freeze routine. Conversely, if either of these conditions is exceeded after the valve is held, Freeze mode will be disabled, the valve will move, and the timer will be reset.

Freeze mode is inhibited during start-up and shutdown (sequence positioning), when in Full Manual or Manual with Backup control modes, if the anti-surge valve is closed ( $<2\%$ ), and when the operating point is far from the Surge Control Line ( $S\_PV > 115$ ).

### Valve Overstroke

Some applications may require positive seating of the anti-surge valve in the fully open and closed positions. If enabled, over-stroke will add the configured “Overstroke Amount Open” to the valve position once it reaches 99.8% open. If, for example, the over-stroke amount is tuned to 5%, the valve demand will step to 105% once the control output reaches 99.8%. Conversely, the “Overstroke Amount Closed” value is subtracted from the control output once it reaches 0.2% open. If the same 5% were tuned for the closed position, a control output of 0.2% would yield a valve demand of  $-5\%$ , positively seating the valve closed.

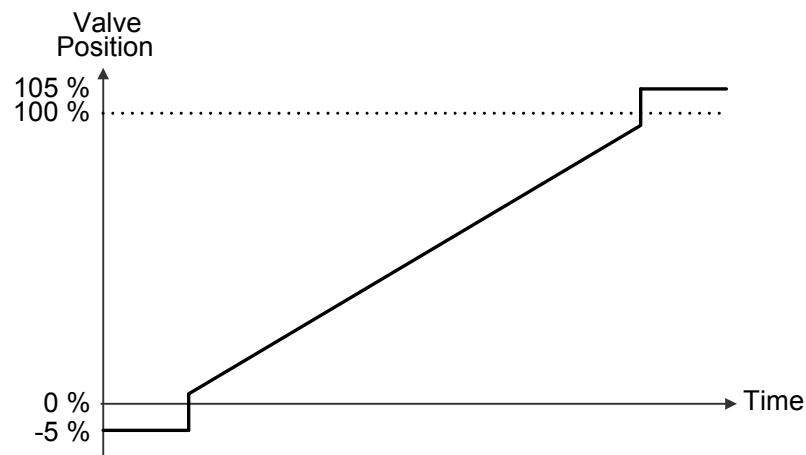

Figure 2-28. Valve Overstroke

### Valve Dither

Many valve designs can develop memory if their positions remain constant for long periods of time. Other mechanical, electrical, or electro-mechanical devices in the anti-surge valve's 4–20 mA loop, such as current to pneumatic transducers (I/Ps), can also suffer from this phenomenon. Mechanical inertia also plays a role, particularly in large anti-surge valves with tight seals. The combination of these factors is often referred to as stiction, and can be detrimental to good control, especially in high gain systems requiring fine valve control. For applications susceptible to this condition, the 505CC-2 offers a dither function added to the valve demand output. Dither applies a 12.5 Hz signal of configurable amplitude onto the valve demand. Figure 2-29 shows a 0.5% dither applied to a constant 39.5% valve output. Dither, if applied, should not be visible as movement in the valve. The dither function is always active—Configure the “Amount” to 0.0% for no dither.

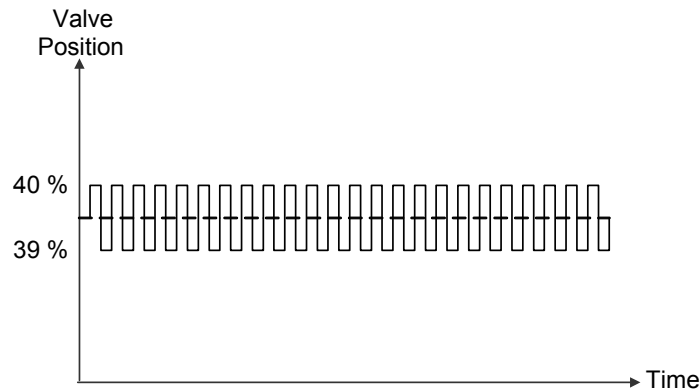

Figure 2-29. Valve Dither

### Valve Characterization

Valve characterization plays an important role in any control application. Because of tuning concerns and the wide operating range of most compression processes, linear anti-surge valves are generally preferred. However, quick opening, equal-percentage, and other valve characterizations are prevalent, especially as line sizes increase and globe valves become cost prohibitive. Alternative rotary valves are rarely able to produce a truly linear response. As a result, an eleven-point linearization block is provided to characterize the demand output to the anti-surge valve's flow characteristics.

See Figure 2-30 for a sample equal percentage valve characteristic and the corresponding linearization curve that results in a linear flow characteristic.

### Pre-Pack

Pre-pack is used on applications where long piping runs and large tanks create a significant system lag. In other words, the time between a movement of the anti-surge valve and a change in the operating point is large because of process delays. The 505CC-2 can compensate for this if the system is lag limited, but not if it is rate limited. Rate limited means that the system will only react at a set rate, regardless of how quickly the valve acts. Lag limited means the system has no measurable response for a set time, and then at some point, a response is measured.

To help overcome this control lag, the Pre-Pack routine will over-stroke the anti-surge valve momentarily at the beginning of the BOOST and Surge Recovery responses. This temporary overreaction can reduce the total response time of the system. See Figure 2-31 for a sample valve output illustrating a BOOST response with Pre-Pack enabled.

Original Valve Demand (Valve % Stroke)	Inherent Equal Percentage Valve Characteristic (% of Max Flow)	Linearization Curve (Y-values) (Valve % Stroke)
0	0	0
10	5	30
20	7	52
30	10	64
40	14	72
50	19	77
60	25	81
70	37	86
80	57	91
90	78	95
100	100	100

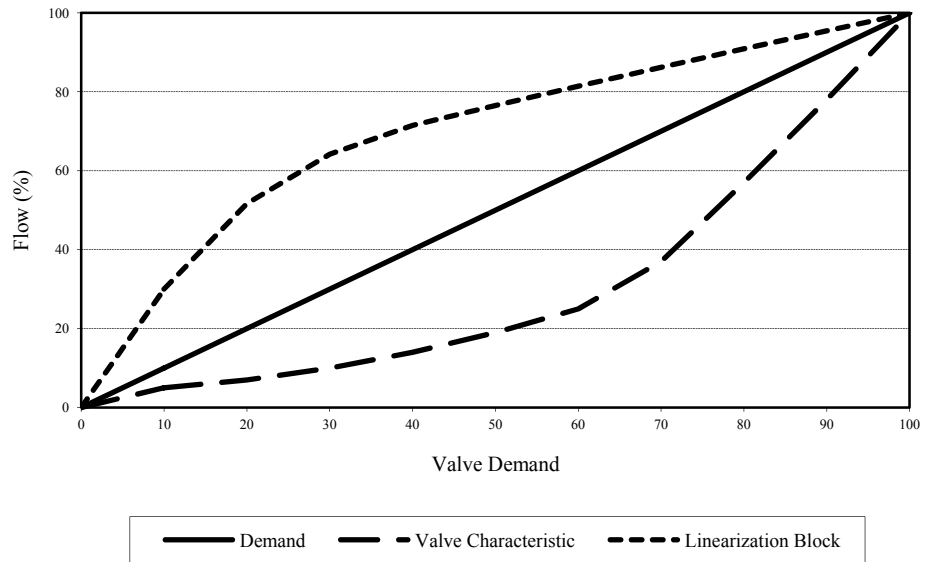

Figure 2-30. Valve Characterization

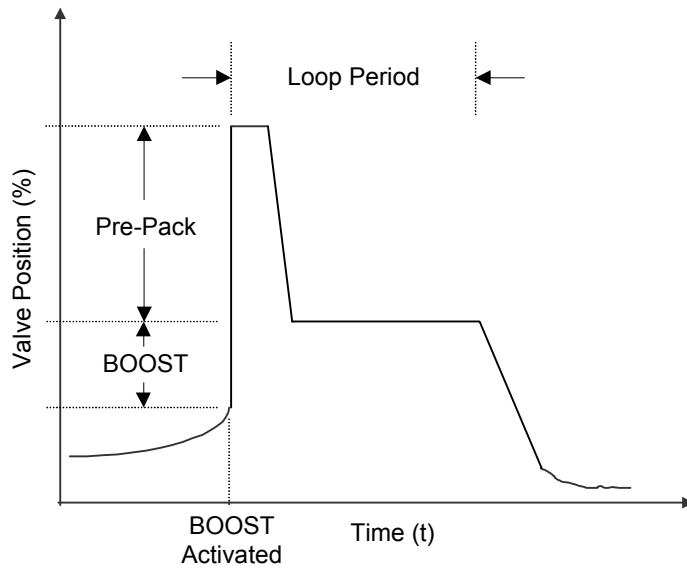

Figure 2-31. BOOST Response with Pre-Pack

This routine should be enabled only if it is determined that the response time of the system is excessive (greater than 10 seconds) and if the system will respond to this action as described. In some cases the anti-surge valve or other components in the system are the limiting factors, which will not be affected by this routine. A value of 10% to 40% is common, depending on the system's ability to react and process stability required. Refer to the Loop Period Test Procedure in Chapter 4.

### Deactivation

If a routine is abruptly disabled while in control of the anti-surge valve or control is transferred from one routine to another, the deactivation function provides for a smooth transition of the valve demand output. Deactivation is an internal function that only occasionally has control of the valve--It is mentioned here merely for explanation.

### Compressibility Calculation (Standard Algorithm)

If the Standard Algorithm is selected, the gas compressibility must be known to calculate the individual parameters of head and flow correctly. The compressibility may be entered as default values for suction (Z1) and discharge (Z2) conditions and used as constants, or it may be calculated on-line, in which case the critical temperature and pressure of the process gas are required. If the on-line calculation is utilized, then one value is calculated for the flow sensor conditions, a second value for the compressor inlet, and a third for the compressor outlet. If the default values are used, compressibility at the flow sensor (Zf) is selected based upon the configured flow element location (suction or discharge). In either case, the calculated average compressibility ( $Z_{avg}=(Z1+Z2)/2$ ) is used for head calculations.

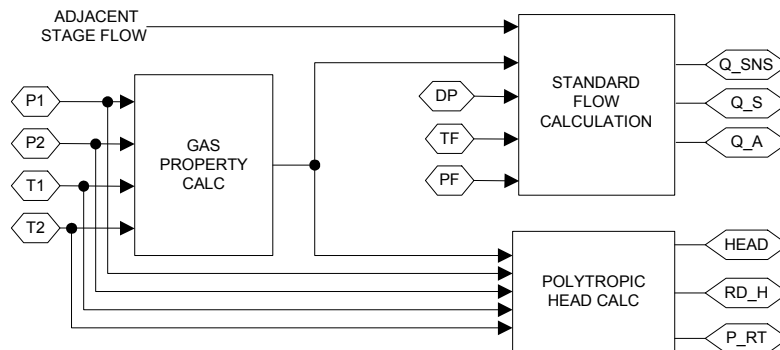

Figure 2-32. Gas Property Calculations

### Specific Heat Ratio Calculation (Standard Algorithm)

If the Standard Algorithm is selected, the specific heat ratio, or isentropic exponent, for the process gas must also be known to calculate the individual parameters of head and flow correctly. Default values for specific heat ratio and efficiency are configured into the control and used in the polytropic head calculation. However, the control will automatically calculate the specific heat ratio from on-line temperature and pressure measurements if the original "Gas Component" configuration is "Variable." This automatic calculation is disabled until the unit is online, when operation is not steady state, and if the calculated value exceeds the configured default  $\pm 0.25$ .

## Alarms

See Table 2-2 for a list of compressor alarms. This list is duplicated for each compressor section. The numerical reference can be used as an index to determine the first alarm received via the first-alarm number in the Datalog or Modbus.

Alarm Number	Alarm Description
0	Alarms Cleared
1	Flow Input Signal Failed
2	Suction Pressure Input Signal Failed
3	Discharge Pressure Input Signal Failed
4	Suction Temperature Input Signal Failed
5	Discharge Temperature Input Signal Failed
6	Flow Element Pressure Input Signal Failed
7	Flow Element Temperature Input Signal Failed
8	Decoupling Input #1 Signal Failed
9	Decoupling Input #2 Signal Failed
10	HSS Auxiliary Input #1 Signal Failed
11	HSS Auxiliary Input #2 Signal Failed
12	Remote Manual Valve Position Input Signal Failed
13	Redundant Flow Input Signal Failed
14	Redundant Suction Pressure Input Signal Failed
15	Redundant Discharge Pressure Input Signal Failed
16	Redundant Flow Inputs Difference Alarm
17	Redundant Suction Pressure Inputs Difference Alarm
18	Redundant Discharge Pressure Inputs Difference Alarm
19	Start Sequence Initiated while in Manual Mode
20	Full Manual Mode Selected without Surge Recovery Enabled
21	Steady State Condition Failed
22	Surge Detected
23	Surge Minimum Position Active
24	Anti-surge Valve Output Fault
25	Invalid Compressor Configuration

Table 2-2. Compressor Alarm List

### High-Speed Datalog

The 505CC-2 includes a high-speed datalogging facility that can assist in troubleshooting a surge or other event. It records all typical data for both compressor loops at a 10-millisecond sample rate. The data that are recorded are fixed. The sample rate can be changed but only with special software tools.

The datalog is a circular buffer that is stored in CPU memory. As shown in Table 3-3, it records 40 discrete values (TRUE/FALSE) and 40 analog values for each compressor, as well as speed. This amount of data sampled every 10ms results in a 32-second datalog. After the buffer is full, the datalog begins overwriting the oldest data. Recording automatically begins when the compressor train is started and automatically stops 10 seconds after a surge or shutdown. Using special software tools, starting and stopping the datalog can also be done manually to record specific transient events, process swings, etc. Two compressor datalogs can be stored on the CPU at any given time—if two completed datalog files already exist, the older of the two will be overwritten by the next datalog file.

AppManager and Control Assistant software, included on the CCT software disc, can be used to retrieve and view the datalogs. (AppManager may also be downloaded from the software page at [www.woodward.com](http://www.woodward.com)) See AppManager's online help menu for details on retrieving files, including datalogs, from the control. The AppManager Datalog Retrieval Tool, available with an extra, purchased license, can also be configured to automatically archive datalogs from the control to a connected network computer. See Control Assistant's online help menu for details on viewing the .log datalog files. The file is a comma delimited text file, so it can also be imported into most trending or spreadsheet software for viewing and data manipulation.

Discrete Values (TRUE/FALSE = 1/0)	Analog Values
Suction Pressure LGV Active	Compressor Speed
Suction Pressure Default Value Active	Filtered Flow Signal
Disch. Pressure LGV Active	Filtered Suction Pressure Signal
Disch. Pressure Default Value Active	Filtered Discharge Pressure Signal
Flow Pressure LGV Active	Filtered Flow Pressure Signal
Flow Pressure Default Value Active	Filtered Suction Temperature Signal
Suction Temperature LGV Active	Filtered Discharge Temperature Signal
Suction Temperature Default Value Active	Filtered Flow Temperature Signal
Discharge Temperature LGV Active	Suction Pressure Value used for Control
Disch. Temperature Default Value Active	Discharge Pressure Value used for Control
Flow Temperature LGV Active	Flow Pressure Value used for Control
Flow Temperature Default Value Active	Suction Temperature Value used for Control
Surge Detected	Discharge Temperature Value used for Control
Surge Detected by Flow Derivative	Flow Temperature Value used for Control
Surge Detected by Suction Pressure Derivative	Ratio of Specific Heats (k)
Surge Detected by Discharge Pressure Derivative	Calculated Sigma Value
Surge Detected by Speed Derivative	Suction Compressibility (Z1)
Surge Detected by Minimum Flow	Flow Compressibility (Zf)
Surge Detected by Surge Limit Line	Calculated Average Compressibility (Zavg)
Surge Minimum Position (SMP) Active	Calculated Flow at Sensor (Qsns)
Sequence – Purge	Calculated Flow thru Stage (Qs)
Sequence – Start	Calculated Actual Inlet Flow (Qa)
Sequence – OnLine	Calculated Corrected Inlet Flow (Q <sub>CR</sub> )
Sequence – Controlled Shutdown	Calculated Polytropic Head (Hp)
Sequence – Emergency Shutdown	Calculated Reduced Head (Hred)
Sequence - Zero Speed	Calculated Pressure Ratio (PR)
Automatic Mode Selected	S_PV Value
Manual w/ Backup Selected	Control Margin Percentage
Full Manual Mode Selected	Gain Compensation Value
AntiSurge Valve Freeze Active	Rate PID Process Value
AntiSurge PID In Control	Rate PID Setpoint Value
Rate PID In Control	Flow Derivative Value Captured at Surge
BOOST In Control	Speed Derivative Value Captured at Surge
Surge Recovery In Control	Suction Pressure Derivative Value Captured at Surge
Manual w/ Backup In Control	Discharge Pressure Derivative Value Captured at Surge
Suction Pressure Override In Control	Operating Point Value Captured at Surge
Discharge Pressure Override In Control	Surge Counter
Auxiliary Input #1 In Control	Decoupling Output
Auxiliary Input #2 In Control	AntiSurge Valve HSS Output
Adjacent Stage Valve In Control	AntiSurge Valve Demand
	Alarm First-Out Indicator

Table 2-3. 505CC-2 Compressor Datalog



## Operating Point Calculations

### Standard Algorithm

The Standard Algorithm operating point for a compressor is simply the volumetric inlet flow squared divided by the polytropic head, shown below. This equation can be expanded to show that it reduces to a form that only contains measurable quantities and constants. This is critical for applications where the gas composition changes. First, the flow term will be explored. Then, the polytropic head calculation is detailed, and the combination of the two is expanded to produce the operating point.

$$\text{OperatingPoint} = \frac{(Q_A)^2}{H_P}$$

Flow can be input to the control in various unit calibrations: flow element differential pressure with or without square-root extraction, normal or standard volumetric flow, or mass flow. The latter two require an external flow computer or transmitter calibration using fixed process data. While these are suitable for simple flow measurement and display, they are not ideal for surge control because of accuracy limitations and response time delays. For these reasons, the preferred flow measurement for surge prevention and control is raw flow element differential pressure without square-root extraction. The calculations described below assume this configuration.

Volumetric inlet flow is calculated in two steps. First the standard/normal volumetric (N·m<sup>3</sup>/hr) or mass (kg/hr) flow through the flow element is calculated using the measurements of flow element differential pressure, pressure at the flow sensor, and temperature at the flow sensor. The selection of standard / normal condition volumetric flow or mass flow is made during initial configuration and will dictate what flow units are displayed on the 505CC-2 operating screens. The mass flow equation, with flowing process parameters substituted for density, is:

$$Q_M = N \cdot C \cdot Y \cdot d^2 \cdot \sqrt{\frac{h_f \cdot P_f \cdot MW}{R_g \cdot T_f \cdot Z_f \cdot (1 - \beta^4)}}$$

where:

QM is mass flow

N is a unit sizing factor

C is the flow element Discharge Coefficient

Y is the flow element Gas Expansion Factor

d is the flow element bore

hf is the differential pressure across the flow element

Pf is the gas pressure at the flow element

MW is the gas molecular weight

Rg is the Universal Gas Constant

Tf is the gas temperature at the flow element

Zf is the gas compressibility at the flow element

β is the flow element Beta ratio (bore divided by pipe internal diameter)

Combining constant parameters, the equation is rewritten as:

$$Q_M = \frac{N \cdot C \cdot Y \cdot d^2}{\sqrt{R_g \cdot (1 - \beta^4)}} \cdot \sqrt{\frac{h_f \cdot P_f \cdot MW}{T_f \cdot Z_f}}$$

$$Q_M = K_M \cdot \sqrt{\frac{h_f \cdot P_f \cdot MW}{T_f \cdot Z_f}}$$

where:

KM is a mass flow constant, combining other constant values

The flow constant (KM) and Molecular Weight (MW) are input to the control during initial configuration. Flow element differential (hf), pressure (Pf), and temperature (Tf) are measured. As discussed previously, compressibility (Zf) is either configured as a constant or calculated on-line.

If, instead of mass flow, normal volumetric flow is selected during configuration, the calculation is similar:

$$Q_{nor} = \frac{Q_M}{\rho_{nor}} = \frac{N \cdot C \cdot Y \cdot d^2 \cdot \sqrt{\frac{h_f \cdot P_f \cdot MW}{R_g \cdot T_f \cdot Z_f \cdot (1 - \beta^4)}}}{\frac{P_{nor} \cdot MW}{R_g \cdot T_{nor} \cdot Z_{nor}}}$$

where:

Qnor is normal volumetric flow

pnor is the normal condition gas density

Pnor is the normal condition gas pressure

Tnor is the normal condition gas temperature

Znor is the normal condition gas compressibility

Combining constant parameters, the equation is rewritten as:

$$Q_{nor} = N \cdot C \cdot Y \cdot d^2 \cdot \sqrt{\frac{h_f}{1 - \beta^4}} \cdot \frac{P_f \cdot MW}{R_g \cdot T_f \cdot Z_f} \cdot \frac{R_g \cdot T_{nor} \cdot Z_{nor}}{P_{nor} \cdot MW}$$

$$Q_{nor} = \frac{N \cdot C \cdot Y \cdot d^2 \cdot T_{nor} \cdot Z_{nor} \cdot \sqrt{R_g}}{P_{nor} \cdot \sqrt{1 - \beta^4}} \cdot \sqrt{\frac{h_f \cdot P_f}{T_f \cdot Z_f \cdot MW}}$$

$$Q_{nor} = K_{nor} \cdot \sqrt{\frac{h_f \cdot P_f}{T_f \cdot Z_f \cdot MW}}$$

where:

Knor is a normal volumetric flow constant, combining other constant values

As seen in these equations, the selection of mass or normal volumetric flow will affect the calculation of the flow constant (KM or Knor), which is input to the control during initial configuration. While this calculation is performed automatically by the HMI/CCT, the equations are provided here for verification:

$$K_M = 0.0438521 \cdot \frac{C \cdot Y \cdot d^2}{\sqrt{(1 - \beta^4)}}$$

If Mass Flow is selected:

$$K_{nor} = 0.9829 \cdot \frac{C \cdot Y \cdot d^2}{\sqrt{(1 - \beta^4)}}$$

If Normal Volumetric Flow is selected:

**IMPORTANT**

These formulas for calculating flow constants assume SI engineering units of kPa, °C, kg/hr, m<sup>3</sup>/hr, and mm. This matches the required inputs of the 505CC-2. These constants will be different when compared to other flow measurements in different engineering units.

If an annubar is used as the flow element, substitute pipe internal diameter (D) for bore diameter (d) and 0 for beta ratio ( $\beta$ ) in these equations.

Beta ratio ( $\beta$ ), flow element bore (d, millimeters), Discharge Coefficient (C), and Gas Expansion Factor (Y) are all taken from the Flow Element Calculation or Data Sheets. The latter value, but to some degree all four, will vary with process conditions and flow rate. And, flow element calculations are often made at a maximum flow condition for calibration of the flow (differential pressure) transmitter. As such, the flow element calculation sheet's data may not be relevant to normal compressor operation. If possible, maximum accuracy is achieved by selecting these "constants" that correspond to the compressor's normal operating conditions and flow rate. The numerical constants are calculated from the Universal Gas Constant (Rg), N-factor (N), and normal condition process parameters in SI units.

The calculated normal/standard volumetric or mass flow through the flow element can then be combined with any side-stream or adjacent stage flows resulting in the total flow through the compressor stage, Qs. However, actual volumetric suction flow is necessary to plot on the chosen compressor map, so the conversion is made with the one of the following equations:

$$Q_A = \frac{Q_S}{\rho_1} = \frac{Q_S \cdot R_g \cdot T_1 \cdot Z_1}{P_1 \cdot MW}$$

If Mass Flow is selected

$$Q_A = Q_S \cdot \frac{P_{nor}}{P_1} \cdot \frac{T_1}{T_{nor}} \cdot \frac{Z_1}{Z_{nor}}$$

If Normal Volumetric Flow is selected

where:

QA is actual volumetric suction flow

QS is total compressor stage flow (normal or mass)

$\rho_1$  is the gas density at suction conditions

T1 is the gas temperature at suction conditions

Z1 is the gas compressibility at suction conditions

P1 is the gas pressure at suction conditions

Tnor is the normal condition gas temperature

Znor is the normal condition gas compressibility

Pnor is the normal condition gas pressure

By substituting the flow sensor calculation (Qs), the result is:

$$Q_A = K \sqrt{\frac{T_1^2 \cdot Z_1^2}{P_1^2} \cdot \frac{h_f \cdot P_f}{T_f \cdot Z_f \cdot MW}}$$

where:

K is a combination of those flow constants calculated previously, for mass or normal volumetric flow (KM or Knor), and the Universal Gas Constant (Rg) or normal condition process parameters (Tnor, Pnor, Znor)

Assume, for example, that the flow element is located in the compressor suction line ( $f=1$ ). The equation can be simplified as:

$$Q_A = K \sqrt{\frac{T_1 \cdot Z_1 \cdot h}{P_1 \cdot MW}}$$

In order to determine the second half of the operating point, the following equation is used to calculate the polytropic head for the compressor.

$$H_P = \frac{R_g \cdot T_1 \cdot Z_{avg}}{MW} \cdot \frac{\left(\frac{P_2}{P_1}\right)^\sigma - 1}{\sigma}$$

Where:

HP is polytropic head

Zavg is the average gas compressibility for the compressor

P2 is the gas pressure at discharge conditions

$\sigma$  is the polytropic exponent which can be defined as:

$$\sigma = \frac{k-1}{k \cdot \eta_p} = \frac{\ln\left(\frac{T_2}{T_1} \cdot \frac{Z_2}{Z_1}\right)}{\ln\left(\frac{P_2}{P_1}\right)} \cong \frac{\ln\left(\frac{T_2}{T_1}\right)}{\ln\left(\frac{P_2}{P_1}\right)}$$

Where:

k is the specific heat ratio, or isentropic exponent, of the gas

$\eta_p$  is the polytropic efficiency of the compressor

T2 is the gas temperature at discharge conditions

Z2 is the gas compressibility at discharge conditions

After volumetric flow and polytropic head have been calculated, the controller can now combine these two values and calculate a single value representing the operating point of the compressor. If this is continued in equation form we have the following:

$$\text{OperatingPoint} = \frac{(Q_A)^2}{H_P} = \frac{K^2 \cdot T_1^2 \cdot Z_1^2 \cdot h_f \cdot P_f}{P_1^2 \cdot T_f \cdot Z_f \cdot MW} \cdot \frac{R_g \cdot T_1 \cdot Z_{avg} \cdot \left(\frac{P_2}{P_1}\right)^\sigma - 1}{MW \cdot \sigma}$$

Now it can be seen that several of the terms on the top and bottom of the ratio can be canceled out. The gas molecular weight (MW) cancels out of the numerator and denominator. In most cases, the gas compressibility does not change much between the suction and discharge, so the compressibility terms may be canceled with little or no error introduced. This leaves the following equation:

$$\text{OperatingPoint} = \frac{K^2 \cdot T_1 \cdot P_f \cdot h_f \cdot \sigma}{R_g \cdot T_f \cdot P_1^2 \cdot \left(\left(\frac{P_2}{P_1}\right)^\sigma - 1\right)}$$

K and  $R_g$  are constants that do not change, and all that remain are measured variables.

As for  $\sigma$ , this requires another calculation but it is still found from measured values. The following equation is the relationship between pressures and temperatures for an isentropic process such as compression.

$$\sigma = \frac{\ln\left(\frac{T_2}{T_1}\right)}{\ln\left(\frac{P_2}{P_1}\right)}$$

The only additional parameter not mentioned previously is discharge temperature. Therefore, this measurement is necessary if the gas composition passed through the compressor is expected to change. That is, if the “Gas Component” configuration is “Variable,” then temperature measurements are required in the suction and discharge. Conversely, if the “Gas Component” configuration is “Constant,” then, at a minimum, a temperature measurement is required in the location of the flow element (suction or discharge). If only one temperature measurement is available, the control will automatically calculate the other temperature using the relationship of  $\sigma$  ( $\sigma$ ), described above, or from a mass balance flow equation. Then all of the necessary parameters for calculating an accurate operating point are measured and variances compensated.

### Universal Algorithm

Calculation of the Standard Algorithm operating point, volumetric inlet flow squared divided by polytropic head, is especially important to achieving accuracy when the gas composition is expected to change. However, the Universal Algorithm, with its corrected flow, was developed for its immunity to such variances. At a given compressor pressure ratio, the inlet volumetric flow will change with temperature, compressibility, and molecular weight. But, by appropriate manipulation of the volumetric flow equation, we can compensate for variations in suction gas conditions without actually measuring the changes in temperature, compressibility, and molecular weight. The result is a corrected flow variable that is indicative of compressor flow at the suction conditions of the reference performance map used for antisurge control.

Starting with the flow equations presented earlier:

$$Q_A = \frac{Q_M}{\rho_1} = N \cdot C \cdot Y \cdot d^2 \cdot \sqrt{\frac{h_f \cdot P_f \cdot MW}{R_g \cdot T_f \cdot Z_f \cdot (1 - \beta^4)}} \cdot \frac{R_g^2 \cdot T_1^2 \cdot Z_1^2}{P_1^2 \cdot MW^2}$$

Assume, for example, that the flow element is located in the compressor suction line ( $f=1$ ). The equation can be simplified as:

$$Q_A = \frac{N \cdot C \cdot Y \cdot d^2}{\sqrt{1 - \beta^4}} \cdot \sqrt{\frac{h_f \cdot R_g \cdot T_1 \cdot Z_1}{P_1 \cdot MW}}$$

The corrected flow variable eliminates the process parameters (T, Z, MW) as follows:

$$Q_{CR} = \frac{Q_A}{\sqrt{R \cdot T_1 \cdot Z_1}} = \frac{Q_A}{\sqrt{\frac{R_g}{MW} \cdot T_1 \cdot Z_1}} = K_{CR} \cdot \sqrt{\frac{h_f}{P_1}}$$

Corrections are made online for alternate flow element pressure sensors or for flow elements located in the compressor discharge. The result is a much simpler operating point calculation, which is the corrected flow itself:

$$\text{OperatingPoint} = Q_{CR} = K_{CR} \sqrt{\frac{h_f}{P_f} \cdot \frac{P_f}{P_1}}$$

For Suction Flow Elements:

$$\text{OperatingPoint} = Q_{CR} = K_{CR} \sqrt{\frac{h_f}{P_f} \cdot \frac{P_f}{P_2} \cdot \left(\frac{P_2}{P_1}\right)^{\frac{n+1}{2n}}}$$

For Discharge Flow Elements:

where:

QCR is the corrected volumetric suction flow

KCR is the corrected flow constant

hf is the differential pressure across the flow element

Pf is the flow element pressure (if other the P1 or P2)

P1 is the compressor suction pressure

P2 is the compressor discharge pressure

n is the polytropic exponent, calculated from sigma ( $\sigma$ ) as:

$$n = \frac{1}{1 - \sigma}$$

As can be seen in these equations, all parameters are measured except for the corrected flow constant (KCR) and polytropic exponent (n). Since the corrected

flow variable ( $\frac{Q_A}{\sqrt{RTZ}}$ ) is equal for all process conditions (RTZ) at a given pressure ratio, the corrected flow constant (KCR) and polytropic exponent (n) are calculated for the compressor performance map's rated or reference condition and configured into the control.

# Chapter 3.

## Compressor Control General Description

### Introduction

The 505CC-2 interfaces with a compressor's recycle, or anti-surge, valve to control a compressor section relative to its performance map surge line. Two compressor sections, or loops, with a variety of instrument locations can be accommodated (See Appendix A and the 505CC-2 Configuration—Comp General section in Chapter 4). The user may choose either of two compressor map implementations, the Standard Performance Map Algorithm or Universal Performance Map Algorithm, described in detail in Chapter 2. Either algorithm will accurately represent the current compressor operating point. The 505CC-2 compressor control can also assist process control functions to boost compressor suction pressure or limit discharge pressure by modulating the compressor anti-surge valve.

Configuration and operation are available through the provided Configuration Tool (CCT) software running on any connected computer, or on an optional 15 inch (381 mm) touch-screen HMI (Human Machine Interface). Additional operational and monitoring capabilities are available over serial Modbus.

### Additional Features

The 505CC-2 also provides the following features:

- The calculation of gas properties such as specific heat ratio ( $k$ ) and compressibility ( $Z$ ) are available for additional accuracy in the Standard Algorithm.
- Four robust surge detection routines detect a surge within 50 milliseconds. These user-configurable surge detection routines are flow derivative (rate of change), speed derivative (rate of change), suction pressure derivative (rate of change), and discharge pressure derivative (rate of change). Additionally, the anti-surge valve may be opened once the compressor operating point reaches the configured Surge Limit Line or flow drops below a configured minimum value, whether or not surge has been detected by the other routines.
- Transmitter failures automatically initiate backup routines to provide redundancy style protection without extra hardware. Upon a signal failure, the 505CC-2 analyzes the compressor operation for stability to determine if the last good value is viable, otherwise default values are used. Even if every transmitter except flow fails, the 505CC-2 can still provide surge protection in automatic, based upon a flow derivative surge signature. Optionally, other signal failures can initiate the same Fail to Manual backup routine as a flow failure, providing the most conservative protection strategy.
- Bump-less transfer between three control modes is provided: Automatic, Manual with Backup, and Manual. The controller can fully automate the process; allow manual anti-surge valve control with backup protection override, or provide full manual control for maintenance purposes.
- To stabilize interrelated processes, Decoupling routines are provided between the anti-surge valve and speed (fast and slow), as well as from a second valve. Two additional decoupling routines can be configured from external sources.

- Start-up and shutdown sequencing of the anti-surge valve, including an optional purge position, provide complete compressor control from zero speed to full loading.

## 505CC-2 Inputs and Outputs

### Control Inputs

Fifteen (15) 4–20 mA analog inputs are available. One (1) through five (5) are fixed as Flow, Suction Pressure, Discharge Pressure, Suction Temperature, and Discharge Temperature for Compressor 1. Six (6) through ten (10) are also fixed, repeating the previous for Compressor 2. Eleven (11) through fifteen (15) are configurable for the following options for both compressor sections:

- Raw Input Signal PF—The Flow Element Pressure input may be used for a pressure transmitter at the flow element, if its location is far from the compressor suction or discharge pressure measurements.
- Raw Input Signal TF—The Flow Element Temperature input may be used for a temperature transmitter at the flow element, if its location is far from the compressor suction or discharge temperature measurements.
- Decoupling Input #1—Auxiliary Decoupling inputs are provided for limited feed-forward biasing of the anti-surge valve, based upon a separate process change.
- Decoupling Input #2—Auxiliary Decoupling inputs are provided for limited feed-forward biasing of the anti-surge valve, based upon a separate process change.
- HSS Aux Input #1—Auxiliary HSS (High Signal Select) inputs are provided for anti-surge valve positioning (0% = Closed, 100% = Open) in Automatic Mode.
- HSS Aux Input #2—Auxiliary HSS (High Signal Select) inputs are provided for anti-surge valve positioning (0% = Closed, 100% = Open) in Automatic Mode.
- Remote Vlv Position—Remote valve positioning (0% = Closed, 100% = Open) in Manual Modes.
- Redundant Flow—Accommodates a redundant flow transmitter.
- Redundant Suction Pressure—Accommodates a redundant suction pressure transmitter.
- Redundant Discharge Pressure—Accommodates a redundant discharge pressure transmitter.

Twelve (12) contact inputs are available, four (4) of which are fixed for manual open and close commands for two anti-surge valves. The eight (8) remaining contact inputs are configurable for the following options for both compressor sections:

- Reset SMP (momentary)—Resets the Surge Minimum Position hold on valve position.
- Reset Surge Info (momentary)—Resets the Surge Capture information (counter, signature values)—Does not reset the Total Surges Counter.
- Select AUTO (momentary)—Selects the Automatic control mode.
- Select MAN w/ BKUP (momentary)—Selects the Manual with Backup control mode.
- Select FULL MANUAL (momentary)—Selects the Full Manual control mode.
- Purge Position (sustained)—Selects the anti-surge valve's Purge position during start-up.



- OnLine Aux Input (sustained)—Initiates the transition from sequence positioning control to automatic anti-surge control (starts the anti-surge control instead of, or in addition to, using speed, flow, or pressure setpoints).
- Add Margin – Inc (momentary or sustained)—Increases the current Control Margin by 0.1% per second while the input is closed.
- Add Margin – Dec (momentary or sustained)—Decreases the current Control Margin by 0.1% per second while the input is closed (cannot decrease below the configured Base Control Margin).
- AS Valv Cntl Out Flt (sustained)—Anti-Surge Valve output fault, which will force the control into Full Manual Mode and move the valve output to the shutdown position. The control cannot detect open- or short-circuits on the 4–20 mA anti-surge valve outputs. This discrete input configuration is provided for an external circuit monitoring device to signal such a fault.
- Start (momentary)—Initiates a compressor “start” by positioning the anti-surge valve in the configured start position from zero-speed. Also acts as a restart command when received after a shutdown but before slowing to zero-speed.
- Shutdown (momentary or sustained)—Initiates a compressor shutdown by positioning the anti-surge valve in the configured shutdown position. Restarts are inhibited if the input is sustained.

## Control Outputs

Two (2) 4–20 mA actuator outputs are provided, one for each anti-surge valve. While the default valve configuration is fail-open (4 mA=Open, 20 mA=Closed), the control can be configured for a fail-closed valve. However, in this case, action must be taken by other devices to open the valve if the control fails or loses power (i.e. output current falls below 4 mA or the configured minimum). A failed actuator output, such as an open- or short-circuit, cannot be detected—A configurable discrete input, as described above, may be used to provide output failure indication to the control from a separate circuit monitoring device.

Two (2) additional configurable analog outputs are provided for readouts of any of the following parameters for both compressor sections:

- S\_PV—Surge Process Variable value.
- Inlet Flow (Standard Algorithm)—Volumetric Inlet Flow.
- Corr Inlet Flow (Universal Algorithm)—Corrected Volumetric Inlet Flow.
- Stage Flow (Standard Algorithm)—Total Mass or Normal/Standard Volumetric Flow through the compressor section (Adjacent Section Flow ± Sensor Flow).
- Polytropic Head (Standard Algorithm)—Calculated Polytropic Head.
- Pressure Ratio Calculated Pressure Ratio across the compressor section.
- P1 Control Value—Suction Pressure value after redundancy management (if applicable), filtering, and failure routines.
- P2 Control Value—Discharge Pressure value after redundancy management (if applicable), filtering, and failure routines.
- T1 Control Value (Standard Algorithm)—Suction Temperature value after filtering and failure routines.
- T2 Control Value (Standard Algorithm)—Discharge Temperature value after filtering and failure routines.
- Sensor Flow (Standard Algorithm)—Calculated Mass or Normal/Standard Volumetric Flow through the flow sensor (Standard Algorithm).
- Valve HSS Output—Output of the High Signal Select bus for all automatic control routines.
- Valve Demand %—Final valve demand including Decoupling and Freeze routines (excludes valve overstroke, dither, and linearization).

Six (6) configurable discrete outputs are available with a variety of assigned functions. These outputs are low-side relay drivers providing up to 200 mA and powered by an external +12 Vdc or +24 Vdc (9–32 Vdc). The outputs are not isolated from each other but are isolated from the control's internal power supplies.

- Surge Detected—Surge has been detected.
- SMP Active—Surge Minimum Position is active.
- OnLine—The Anti-Surge control is OnLine and active.
- AUTO Mode—The control is in Automatic Mode.
- MANUAL w/ BKUP Mode—The control is in Manual w/ Backup Mode.
- FULL MANUAL Mode—The control is in Full Manual Mode.

## Anti-Surge Control Recommendations

Compressor control systems are but one element in the entire anti-surge control loop. Particularly, field instrumentation and final control elements (anti-surge valves) often do not receive an appropriate level of attention during the design phase of the compressor system. Speed of response and sophisticated software routines are the primary differentiators that set compressor controls apart from typical process controls. But, users often rely on “typical” process equipment for transmitters and valves, while spending significant time and resources to select the control system. The speed and accuracy of the entire control loop, including instruments and valves, is critical—The system is only as good as its weakest link.

With this in mind, the following recommendations are provided as a reminder to look at the entire control loop when designing a fast, accurate, and reliable anti-surge control system. These recommendations are not intended to replace good engineering analysis but do provide typical, industry accepted guidelines.

**Instrumentation**—Speed is the primary factor in selecting transmitters. Most compressor systems will utilize analog electronic transmitters with time constants from about 250 milliseconds. As a comparison, pneumatic transmitters can have time constants of several seconds, which obviously eliminates their use in surge protection. As digital transmitters have become more prominent, it is becoming increasingly more difficult to procure their analog predecessors. The extra signal processing in these transmitters add time, albeit small amounts, to the loop response. For the fastest response, some diffused silicon sensors can have time constants as short as 10 milliseconds. Impulse lines should be kept as short as possible, and transmitters should be mounted above the process line to promote liquid drainage. Proper application of the flow element should be followed—Upstream pipe run recommendations or the use of flow conditioners not only improve accuracy but also reduce signal noise.

**Anti-surge Valve**—Anti-surge valves should be sized properly, capable of flowing the full capacity of the compressor at reduced pressure. A typical valve sizing coefficient ( $C_v$ ) is roughly double the highest surge limit line flow. Stroking speeds are typically 2 seconds or less from closed to fully open. This often requires the use of volume boosters, particularly on larger valve sizes, for normal operation. Linear valves are preferred, but non-linear valves can be characterized within the control software. Positioners can be problematic in anti-surge applications, but their use is sometimes required because of the type of valve being used—Consult with the valve manufacturer carefully. Noise abatement may be required in some applications.

# Chapter 4.

## Compressor Configuration Overview

### Introduction

The 505CC-2 may be configured using the Configuration Tool (CCT) software running on a connected computer or via the optional 15" display. See Manual 26240V1 for a description of system level configuration and Volume 2 for turbine configuration. This chapter will provide detailed information concerning the compressor configuration only.

To facilitate compressor configuration when the turbine may be running uncoupled, access to all compressor configuration parameters is available in the Service Login level. If the turbine/compressor unit is shutdown, configuration may be performed in the Online Configuration login. And, as always, the Offline Configuration login is available to generate a configuration file while disconnected from a control.



**WARNING**

The Service login provides access to all compressor configurables. Extreme caution should be exercised if this level is accessed while the compressor is running.

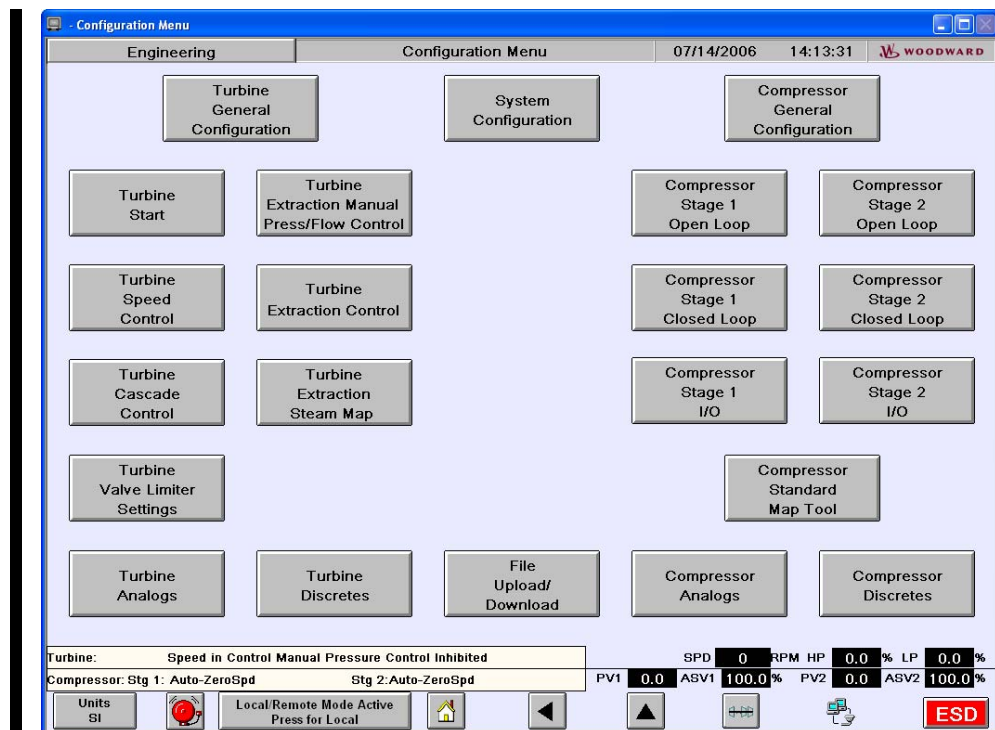

Figure 4-1. Configuration Menu Screen

Depending on the compressor layout and desired control functionality, there are up to ten configuration screens for the compressor train. Screens and individual items are hidden or inhibited based upon the selections made and functions enabled or disabled—Any item that is not selectable is not used in the current configuration. Conversely, any item that is visible and appears selectable should be reviewed to determine its appropriate setting. The configuration items and screens are arranged to facilitate an orderly, sequential configuration, screen by screen, as outlined in the following section.

The default configuration values, except for those that require testing and tuning such as PID gains, Loop Period, etc., are representative of a typical compressor control application. But, virtually every feature can be enabled or disabled and tuned to allow full customization of the control. The Compressor Performance Map(s), API Data Sheet(s), Flow Element Calculation / Data Sheet(s), and a P&ID will be required to properly configure the control. Most configuration can be completed prior to start-up. The exceptions, which require running the compressor for testing, are as follows:

- Loop Period
- Automatic Gain Compensation
- PID Tuning (1 to 4 control loops per compressor section, depending upon configuration)
- Decoupling
- Valve Linearization

After initial configuration, bring the compressor on-line to complete the configuration and tuning of these functions.

## 505CC-2 Compressor Configuration Screens

### Compressor General Screen

The selections on this screen largely determine the appearance of the subsequent configuration and operating screens, as well as the internal software connections for proper control functionality. Some combinations may be invalid, in which case an error message will be displayed and further configuration inhibited. Refer to the configuration rules at the end of this list, or see Appendix A for a complete listing of valid configurations.

- **Altitude Compensation**  
Most internal calculations use absolute pressure measurements. If the pressure inputs (P1, P2, Pf) are calibrated in absolute pressure, check the “Absolute Pressure Inputs” field. Otherwise, leave this field unchecked and adjust the atmospheric pressure offset from its default mean sea level value. This will be added to the gauge pressure input signals to generate absolute pressure values. See Appendix B for a chart of altitude-referenced atmospheric pressures.
- **Suction Pressure Transmitter**  
Often, air compressors are installed without suction pressure transmitters since the suction pressure is known to be constant atmospheric pressure, ignoring barometric fluctuations. Select “Air Compressor without Suction Pressure Transmitter” to force the control to use a constant 101.325 kPaA (or other atmospheric pressure offset, if configured) instead of the 4–20 mA P1 input signal.
- **Algorithm**  
Select the desired Operating Point Calculation Method: “Standard Surge Curve” or “Universal Surge Curve.” For a complete description of each, see Chapter 2.

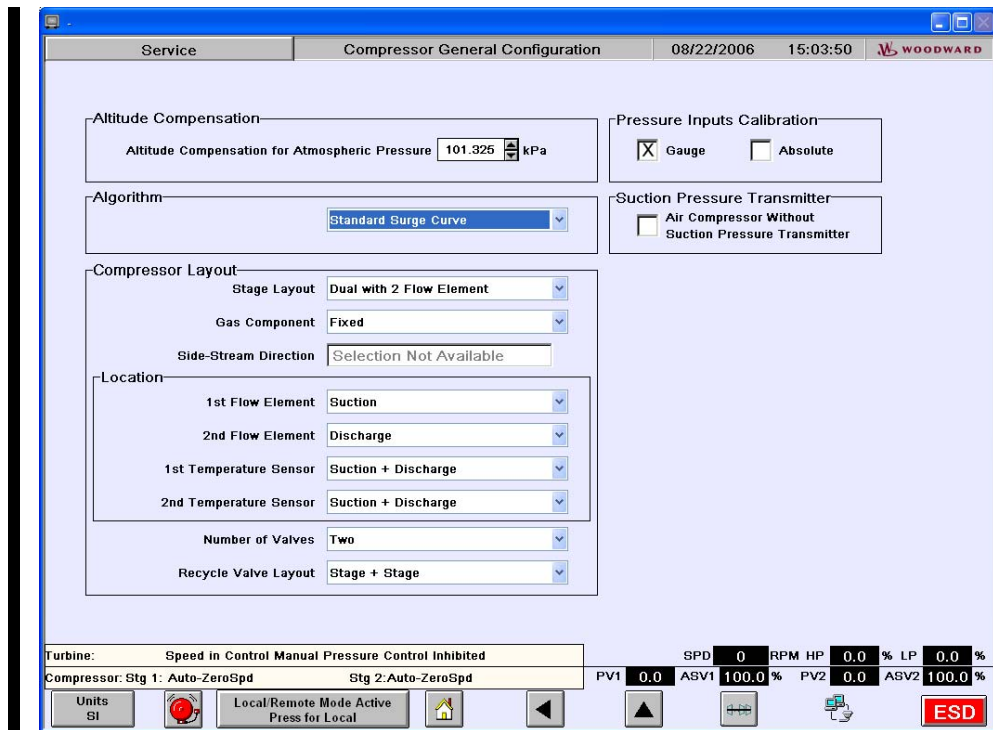

Figure 4-2. Compressor General Configuration Screen

- Stage Layout**  
 Select the appropriate stage layout: “Single,” “Dual with 1 Flow Element,” “Dual with 2 Flow Elements,” or “Dual with SideStream.” “Dual with 1 Flow Element” is not an available selection with the Universal Algorithm. See Figure 4-3 for examples of each layout (instrument locations are shown as examples only).
- Gas Component**  
 Select whether the process gas composition (molecular weight, ratio of specific heats, etc.) is “Constant” or “Variable.” For example, select “Constant” for a closed-loop refrigeration compressor, but a hydrocarbon recycle compressor in a refinery may require “Variable.” This selection is required only for the Standard Algorithm, as the Universal Algorithm is largely immune to gas composition changes. If “Variable” is configured with the Standard Algorithm, temperature measurements are required in both the suction and discharge of the compressor.
- Side-Stream Direction**  
 For “Dual with SideStream” layouts, select “Admission” (flow into the compressor train) or “Extraction” (flow out of the compressor train) for the SideStream direction.
- 1st Stage Flow Element Location**  
 Select the location of the first compressor section flow element as “Suction,” “Discharge,” “SideStream,” or “None.” “None” applies only to “Dual with 1 Flow Element” layouts where the element corresponds to the second compressor section.
- 2nd Stage Flow Element Location**  
 For Dual Stage layouts, select the location of the second compressor section flow element as “Suction,” “Discharge,” “SideStream,” or “None.” “None” applies only to “Dual with 1 Flow Element” layouts where the element corresponds to the first compressor section.

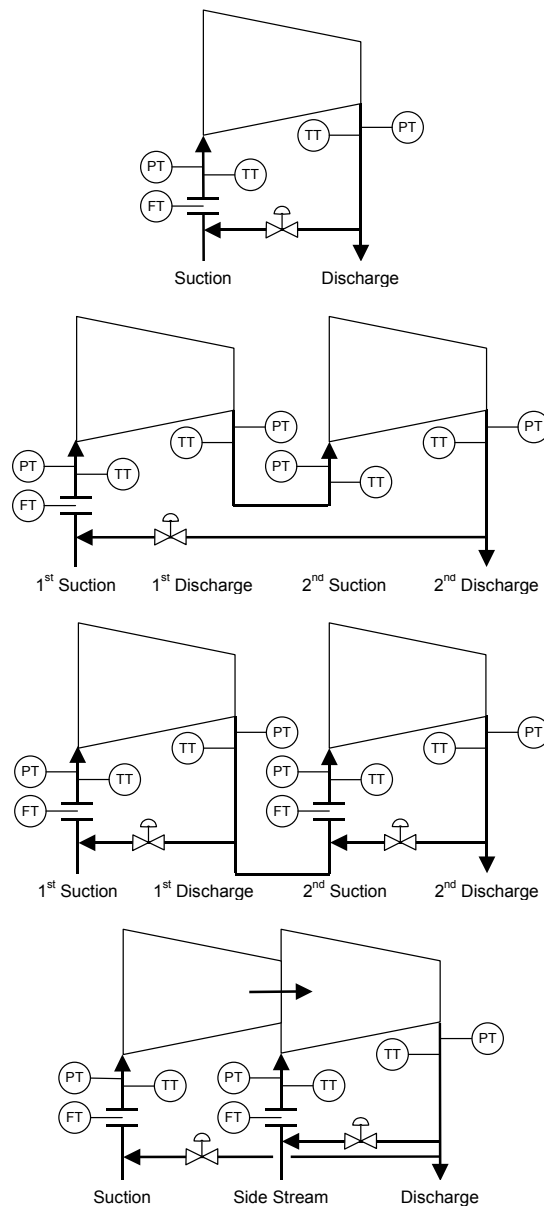

Figure 4-3. Example Compressor Layouts

- 1st Stage Temperature Sensor Location**  
 Select the location of the first compressor section's temperature sensor(s) as "Suction," "Discharge," "Suction + Discharge," "SideStream," or "SideStream + Discharge." This selection is required only for the Standard Algorithm, as temperature sensors are not used for the Universal Algorithm. If the gas composition is "Constant," a temperature measurement is required, at a minimum, at the flow element. If "Variable," temperature measurements are required in both the suction and discharge of the compressor.

- 2nd Stage Temperature Sensor Location**  
 For Dual Stage layouts, select the location of the second compressor section's temperature sensor(s) as "Suction," "Discharge," "Suction + Discharge," "SideStream," or "SideStream + Discharge." This selection is required only for the Standard Algorithm, as temperature sensors are not used for the Universal Algorithm. If the gas composition is "Constant," a temperature measurement is required, at a minimum, at the flow element. If "Variable," temperature measurements are required in both the suction and discharge of the compressor.
- Number of Valves**  
 For Dual Stage layouts, select whether the train has one or two recycle (Anti-Surge) valves. The "Dual with 1 Flow Element" layout is limited to a single valve.
- Anti-surge Valve Layout**  
 For "Dual with 2 Flow Element" layouts and "Two" valves, select the valve layout as "Stage + Stage" (individual recycles), "Stage + Overall" (common suction recycles), or "Overall + Stage" (common discharge recycles). These describe the piping arrangements for the first and second compressor sections' anti-surge valves. See Figure 4-4 for examples.

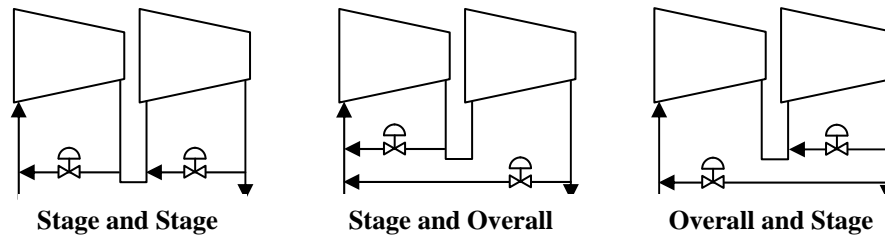

Figure 4-4. Dual with 2 Flow Element Layouts

As shown in Figure 4-5, this configuration is predetermined by the side-stream direction for "Dual with SideStream" layouts with "Two" valves.

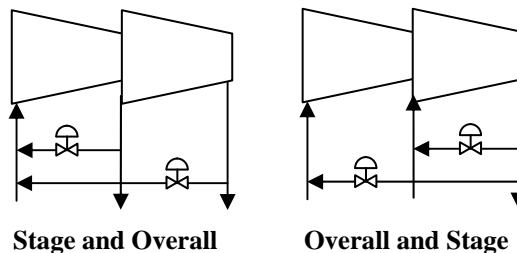

Figure 4-5. Dual with SideStream Layouts

### General Configuration Rules

- "Dual with 1 Flow Element" layouts cannot utilize the Universal Algorithm.
- "Dual with SideStream" layouts can only utilize the Universal Algorithm if the flow elements are in the 1st stage suction and 2nd stage discharge. Otherwise, use the Standard Algorithm and configure the flow element locations appropriately.
- "Dual with SideStream" layouts and "Variable" gas composition cannot utilize the Standard Algorithm.
- The Standard Algorithm requires a temperature measurement(s) in the same location as the flow element(s) (suction, discharge, side-stream) if the gas composition is "Constant." If the gas composition is "Variable," temperature measurements are required in both the suction and discharge.



## Stage 1 Open Loop Screen (same for Stage 2)

The selections on this screen determine surge detection methods, open loop control responses, and sequence positioning of the anti-surge valve.

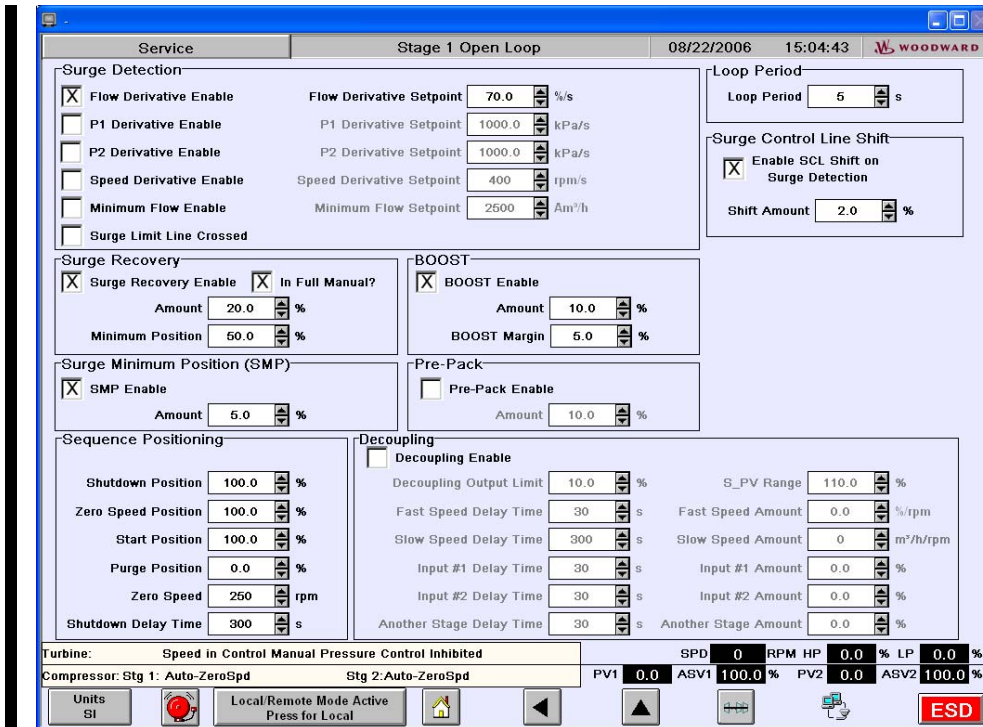

Figure 4-6. Open Loop Configuration Screen

- Surge Detection – If more than one method is enabled, surge will be detected on any single signature. All derivative setpoints are configured in absolute values.

### Flow Derivative

Enable to detect surge on flow derivative, the primary surge signature. The setpoint is configured as a percentage of inlet volumetric flow per second, which means that the flow derivative setpoint changes as flow changes. For example, if the setpoint is configured as 50 %/s and the current calculated flow is 30 000 m<sup>3</sup>/hr, the flow derivative setpoint would be 15 000 m<sup>3</sup>/hr/s at that instant. However, at a flow rate of 10 000 m<sup>3</sup>/hr, the same setpoint configuration would yield a flow derivative setpoint of 5000 m<sup>3</sup>/hr/s. The use of percent per second instead of engineering units per second allows the setpoint to change with compressor loading.

### P1 Derivative

Enable to detect surge on suction pressure derivative. The setpoint is configured as engineering units per second.

### P2 Derivative

Enable to detect surge on discharge pressure derivative. The setpoint is configured as engineering units per second.

### Speed Derivative

Enable to detect surge on speed derivative. The setpoint is configured as rpm per second.



**Minimum Flow**

Enable to 'detect' surge below a minimum flow. Note that surge is not actually detected with this routine—Merely, the Surge Recovery routine is initiated if the calculated flow drops below this Minimum Flow setpoint while the unit is online. The setpoint is configured in engineering units.

**Surge Limit Line Flow**

Enable to 'detect' surge below the Surge Limit Line. Note that surge is not actually detected with this routine—Merely, the Surge Recovery routine is initiated if the compressor Operating Point reaches the configured Surge Limit Line while the unit is online.

- **Loop Period**  
Tune the system response time in seconds. This is the time required for a anti-surge valve position change to be detected in the S\_PV calculation. See the Loop Period Test Procedure at the end of this chapter.
- **Surge Control Line Shift**
- Enable Surge Control Line Shift on Surge Detection to automatically shift the SCL to the right each time a surge is detected. Tune the Shift Amount in percent that will be added to the current control margin for every increment of the surge counter.
- **Surge Recovery**  
Enable to initiate the Surge Recovery routine after a surge has been detected. Tune the "Amount" as the valve opening percentage that is added to the valve position when surge is detected. The final position must be at least that configured as the "Minimum Position." If, for example, the Surge Recovery "Amount" is 20% and the valve is open 18% when a surge is detected, the Surge Recovery response would open the valve to 38%, provided that is above the "Minimum Position"—If not, the valve would open to the "Minimum Position" instead. In other words, when a surge is detected, the Surge Recovery routine will open the valve to the current position plus the Surge Recovery "Amount" or to the "Minimum Position," whichever is greater. Select "In Full Manual?" to enable Surge Recovery when the anti-surge valve is being controlled in Full Manual Mode.
- **BOOST / Valve Step Opening**  
Enable the BOOST routine, or Valve Step Opening, to open the valve when the compressor Operating Point falls too far below the Surge Control Line but before it has reached the Surge Limit Line. Tune the "Amount" as the valve opening percentage that is added to the valve position when the BOOST, or backup, line is crossed. The "BOOST Margin" or "Valve Step Margin," typically five (5) to seven (7) percent, defines the location of the backup line as a percentage of flow to the left of the Surge Control Line.
- **Surge Minimum Position (SMP)**  
Enable SMP to prevent the anti-surge valve from closing after a surge has been detected unless a reset command is issued. Tune the "Amount" as the valve opening percentage that is added to the valve position when surge is detected. If, for example, the SMP "Amount" is configured as 5% and the valve is open 18% when a surge is detected, the control will not allow the valve to close past 23% open until SMP is reset. This SMP "Amount" should be less than the Surge Recovery "Amount" mentioned previously.
- **Pre-Pack**  
Enable Pre-Pack to over-stroke the anti-surge valve momentarily at the beginning of the BOOST or Surge Recovery actions. Tune the Amount as the valve opening percentage that is added to those open-loop responses. See Support Functions in Chapter 2 for more information.

- **Sequence Positioning**
  - Shutdown Position**  
The valve position, in percent open, when a shutdown is received from the Turbine Control or other input. This value also defines the valve demand output if an output failure is detected and input to the control via configurable discrete input. (See Chapter 3 for this function in the list of configurable discrete inputs)
  - Zero Speed Position**  
The valve position, in percent open, after a shutdown, and after the speed drops below the Zero Speed setpoint for the Shutdown Delay time. This is often used to close the anti-surge valve for isolation after a shutdown. If this extra sequence position is unnecessary, configure its value to match that of the “Shutdown Position.”
  - Start Position**  
The valve position, in percent open, during start-up, after a start input is received or the speed increases beyond the Zero Speed setpoint. This is typically 100% open.
  - Purge Position**  
The valve position, in percent open, during start-up, when a purge input is received.
  - Zero Speed**  
The speed setpoint, in rpm, that defines a start-up, or running, condition. This value is used in conjunction with the Zero Speed Position and Start Position described previously.
  - Shutdown Delay Time**  
The delay time, in seconds, after the speed falls below the Zero Speed setpoint, described previously, that determines a zero speed condition. If the Zero Speed Position feature is not being used (Zero Speed Position matches the Shutdown Position) configure the delay time to 0 seconds.
- **Decoupling (See the Anti-Surge Control Routines section of Chapter 2)**  
Decoupling is enabled once for all routines. To eliminate a particular Decoupling action, configure its “Amount” to 0.0. Slow Speed Decoupling is automatically disabled when using the Universal Algorithm. Automatic Gain Compensation (AGC) is applied to Fast Speed Decoupling, so AGC should be configured prior to Decoupling.
  - Decoupling Output Limit**  
The maximum amount, in valve opening percentage, that the sum of all decoupling routines can move the anti-surge valve.
  - S\_PV Range**  
The S\_PV value below which Decoupling is enabled. Above this value, Decoupling is automatically disabled as the compressor is not operating near surge.
  - Fast Speed Delay Time**  
The delay time, in seconds, that Fast Speed Decoupling will remain in effect. After this time delay, the bias will have been removed from the valve demand.
  - Fast Speed Amount**  
The gain, in percent per rpm, by which speed changes are multiplied for Fast Speed Decoupling to modulate the anti-surge valve. Usually, the relationship of speed to S\_PV is direct so this value is set greater than zero.
  - Slow Speed Delay Time**  
The delay time, in seconds, that Slow Speed Decoupling will remain in effect. After this time delay, the bias will have been removed from the valve demand.

**Slow Speed Amount**

The gain, in engineering unit flow per rpm, by which speed changes are multiplied for Slow Speed Decoupling to modulate the anti-surge valve. Usually, the relationship of speed to S\_PV is direct so this value is set greater than zero.

**Input #1 Delay Time**

The delay time, in seconds, that Decoupling from the Auxiliary Input #1 will remain in effect. After this time delay, the bias will have been removed from the valve demand.

**Input #1 Amount**

The gain, in percent per process unit, by which input changes are multiplied for Input #1 Decoupling to modulate the anti-surge valve. This value should be less than zero for inputs that are directly proportional to compressor flow and greater than zero for inputs inversely proportional to compressor flow.

**Input #2 Delay Time**

The delay time, in seconds, that Decoupling from the Auxiliary Input #2 will remain in effect. After this time delay, the bias will have been removed from the valve demand.

**Input #2 Amount**

The gain, in percent per process unit, by which input changes are multiplied for Input #2 Decoupling to modulate the anti-surge valve. This value should be less than zero for inputs that are directly proportional to compressor flow and greater than zero for inputs inversely proportional to compressor flow.

**Another Stage Delay Time**

For Dual Stage, 2-valve trains, the delay time, in seconds, that Another Stage Decoupling from the adjacent stage valve will remain in effect. After this time delay, the bias will have been removed from the valve demand.

**Another Stage Amount**

For Dual Stage, 2-valve trains, the gain, in percent per percent valve demand, by which position changes in the adjacent stage valve are multiplied for Another Stage Decoupling to modulate the anti-surge valve. Similar to the amounts noted above, Another Stage Amounts may be positive or negative depending upon the adjacent valve's effect on compressor flow. This value should be less than zero on Stage 1 for common suction valve layouts and on Stage 2 for common discharge arrangements. Conversely, configure greater than zero on Stage 1 for common discharge valve layouts, on Stage 2 for common suction arrangements, and on both stages with individual recycles.

**Stage 1 Closed Loop Screen (same for Stage 2)**

The selections on this screen tune the four closed loop control responses and determine when automatic control takes over from sequence positioning (online detection).

- **On-Line**—If more than one method is enabled, all must be satisfied to trigger the on-line condition. Loss of any enabled detection method while online will revert the control to the start sequence. All detection methods and setpoints should be chosen conservatively, that is, at a point at which the compressor flow is well above the surge limit, and closing of the anti-surge valve does not initiate instability or surge. When in doubt, always err in the direction of higher speed, flow, and discharge pressure, or lower suction pressure.

The screenshot shows the 'Stage 1 Closed Loop' configuration screen. The top bar displays 'Service Stage 1 Closed Loop', the date '08/22/2006', and the time '15:06:21'. The 'On-Line' section has 'Speed Enable' checked, with a 'Speed Setpoint' of 4800 rpm. Other setpoints include Suction Pressure (1000.00 kPa), Discharge Pressure (1000.00 kPa), and Flow (10000.0 Am<sup>3</sup>/h). The 'Anti-surge PID' section has Prop Gain at 1.000%, Int Gain at 0.100 rps, and Deriv Ratio at 100.000%. The 'Rate Control' section has Rate Control Enable checked, Rate Setpoint at 20.0% (of max rate), Prop Gain at 0.800%, Int Gain at 0.100 rps, and Deriv Ratio at 100.000%. The 'P1 Override' section has P1 Override Setpoint at 10000.0 kPa, Prop Gain at 1.000%, Int Gain at 0.100 rps, and Deriv Ratio at 100.000%. The 'P2 Override' section has P2 Override Setpoint at 0.0 kPa, Prop Gain at 1.000%, Int Gain at 0.100 rps, and Deriv Ratio at 100.000%. The 'Gain Compensation' section has Anti-surge Valve Cv at 1000.00, Normal Value at 10000.0 m<sup>3</sup>/h, and Factor at 1.00. The bottom status bar shows 'Turbine: Speed in Control Manual Pressure Control Inhibited' and 'Compressor: Stg 1: Auto-ZeroSpd Stg 2: Auto-ZeroSpd'. It also displays 'SPD 0 RPM HP 0.0 % LP 0.0 %', 'PV1 0.0 ASV1 100.0 % PV2 0.0 ASV2 100.0 %', and a red 'ESD' button.

Figure 4-7. Compressor Closed Loop Configuration Screen

**Speed**

Enable to begin automatic anti-surge control after compressor speed reaches a configured setpoint. Tune the “Speed Setpoint” in rpm.

**IMPORTANT**

Exercise care when configuring the online detection speed setpoint in relation to the turbine control’s Minimum Governor setting. It is recommended that the online speed setpoint be at least 3% below Minimum Governor and sufficiently within the compressor’s stable operating flow range. Otherwise, the compressor control might lose its online trigger and transition to the start sequence if the speed control were to undershoot Minimum Governor during normal operation because of marginal tuning.

**Suction Pressure**

Enable to begin automatic anti-surge control after suction pressure falls below a configured setpoint. For Stage 2, the suction pressure must exceed this setpoint to go online. Tune the “Suction Pressure Setpoint” in engineering units.

**Discharge Pressure**

Enable to begin automatic anti-surge control after discharge pressure reaches a configured setpoint. Tune the “Discharge Pressure Setpoint” in engineering units.

**Flow**

Enable to begin automatic anti-surge control after compressor suction volumetric flow reaches a configured setpoint. Tune the “Flow Setpoint” in engineering units.

**Aux Input**

Enable to begin automatic anti-surge control once an auxiliary discrete input is received. This configurable discrete input must be a maintained closure.

- **Gain Compensation**
  - Anti-surge Valve Cv**

Tune the “Anti-Surge Valve Cv” to the full-open value. This selection is required only for the Standard Algorithm. The control uses a standard flow equation to calculate flow through the valve. This equation requires temperature measurements, which aren’t used in the Universal Algorithm.
  - Normal Value**

The “Normal Value” corresponds to a full-open anti-surge valve flow for the Standard Algorithm or to the compressor pressure ratio for the Universal Algorithm. With the compressor operating at its normal point, or at the same conditions at which PID controllers are tuned, tune the “Normal Value” until the “Factor” equals 1.00.
  - Factor**

The current calculated Gain Compensation Factor. Where enabled, this value is applied to the configured proportional gains for Anti-Surge, Rate Control, P1 Override, and P2 Override PIDs and in Fast Speed Decoupling.
- **Anti-Surge PID**

Configure the Anti-Surge PID tuning parameters. Proportional Gain is a traditional gain term in percent per unit error. Integral Gain is a traditional reset rate in repeats per second. Speed Derivative Ratio is a derivative based term—While it is available for adjustment, it is recommended that the Derivative Ratio be left at 100.0, which reduces this loop to proportional and integral control. The Rate PID takes the place of the derivative action in the Anti-Surge PID. Enable Automatic Gain Compensation if desired.
- **Rate Control**

Enable the Rate Control PID to provide faster responses to rapid disturbances. Tune the Rate Setpoint factor as a percentage of the maximum allowable rate, which is calculated from Loop Period, or system response time, and the distance to the Surge Control Line. Configure the Rate PID tuning parameters. Proportional Gain is a traditional gain term in percent per unit error. Integral Gain is a traditional reset rate in repeats per second. Speed Derivative Ratio is a derivative based term that determines the degree to which the integral gain is applied to the derivative. Tune to 100.0 for proportional-integral control. Enable Automatic Gain Compensation if desired.
- **P1 Override**

Enable P1 Override to assist the prime mover in regulating (boosting) compressor suction pressure. Tune the P1 Override Setpoint in engineering units. If both the prime mover speed and this P1 Override are used to control suction pressure, it is advised that the P1 Override Setpoint be slightly different than that of the pressure/speed cascade loop to prevent the two controls from interacting unnecessarily. Otherwise, careful tuning of both controllers will be necessary. Proportional Gain is a traditional gain term in percent per unit error. Integral Gain is a traditional reset rate in repeats per second. Speed Derivative Ratio is a derivative based term—While it is available for adjustment, it is recommended that the Derivative Ratio be left at 100.0, which reduces the loop to proportional and integral control. Enable Automatic Gain Compensation if desired.

- **P2 Override**

Enable P2 Override to assist the prime mover in regulating (reducing) compressor discharge pressure. Tune the P2 Override Setpoint in engineering units. If both the prime mover speed and this P2 Override are used to control discharge pressure, it is advised that the P2 Override Setpoint be slightly different than that of the pressure/speed cascade loop to prevent the two controls from interacting unnecessarily. Otherwise, careful tuning of both controllers will be necessary. Proportional Gain is a traditional gain term in percent per unit error. Integral Gain is a traditional reset rate in repeats per second. Speed Derivative Ratio is a derivative based term— While it is available for adjustment, it is recommended that the Derivative Ratio be left at 100.0, which reduces the loop to proportional and integral control. Enable Automatic Gain Compensation if desired.

## Stage 1 I/O Screen (same for Stage 2)

The selections on this screen tune the auxiliary input and output functions, as well as some process data and the base control margin.

The screenshot shows the 'Compressor Stage 1 I/O' configuration screen. The top bar indicates the service name, date (08/22/2006), and time (15:06:51). The main area is divided into several sections:

- Sensor Failure Strategy:** Includes checkboxes for P1, P2, Pf, T1, T2, Tf LGV Enable, and a checked option for 'Fail to Manual on all Sensor Failures'.
- Default Value:** Shows setpoints for P1, P2, Pf (101.33 kPaG) and T1, T2, Tf (0.00 °C).
- Filter Delay Time:** Configures delay times for Flow (0.02 s), Pressure (0.20 s), and Temperature (3.00 s).
- Base Control Margin:** Set to 10.0%.
- Number of Intercooled Sections:** Set to 1.
- Property:** Includes Efficiency (0.870), k Avg (1.420), Z Calculation Enable, Critical Pressure (5000.00 kPaG), and Critical Temperature (0.00 °C).
- Flow:** Includes 'Compensated Signal' (unchecked), 'Differential Pressure (Square Root Calc. Necessary)' (checked), and 'Flow Constant (K)' (12524.0).
- Anti-surge Valve:** Includes 'Invert Output (Fail Open)' (checked), 'Valve Freeze Enable' (unchecked), 'Auto Decay Valve Rate' (0.8 %/s), 'Freeze Delay Time' (120 s), 'HSS Aux #1/2 Enable' (unchecked), and 'Overstroke Enable' (unchecked).
- Manual:** Includes 'Remote Enable' (unchecked), 'Valve Rate' (2.0 %/s), 'Sensor Fail Add'l Amount' (50.0 %), 'Alarm Only on Hi Scale Flow Failure?' (checked), and 'Shutdown Positioning Enable' (unchecked).

The status bar at the bottom shows: Turbine: Speed in Control Manual Pressure Control Inhibited; SPD: 0 RPM HP: 0.0 % LP: 0.0 %; Compressor: Stg 1: Auto-ZeroSpd Stg 2: Auto-ZeroSpd; PV1: 0.0 ASV1: 100.0 % PV2: 0.0 ASV2: 100.0 %.

Figure 4-8. Compressor I/O Configuration Screen

- **Filter Delay Time**

Configure delay times, in seconds, for the first order lag filters of each input type. The flow signal filter is a modified ARMA (Auto Regressive Moving Average). In general, flow signal filter times should be very short, usually 100 milliseconds or less. Pressure signal filters should also be short, but are usually longer (slower) than flow signals. Temperature signals are the slowest of all and can therefore be filtered, if necessary, on the order of seconds. If input signals are clean and stable, filter times can be tuned to 0 to minimize control loop delays.



- **LGV (Last Good Value)**  
Enable or disable the LGV routine for the inputs shown. See the Signal Failure Routines section in Chapter 2 for a complete description of Last Good Value.
- **Default Value**  
Tune fail-safe default values, in engineering units, for the inputs shown. See the Signal Failure Routines section in Chapter 2 for a complete description of how these default values are used.
- **All Inputs Fail to Manual**  
Enable this function to force the control to Manual and step open the anti-surge valve if any input fails (flow inputs fail in this manner by default). See the Signal Failure Routines section in Chapter 2 for a complete description of the Fail to Manual strategy in conjunction with other signal failure responses.
- **Property**  
The parameters in this section are required for the Standard Algorithm head and flow calculations. Tune the Efficiency, k Default (Ratio of Specific Heats), Z1 Default (Suction Compressibility), and Z2 Default (Discharge Compressibility) to their respective values. These can be obtained from the API Compressor Data Sheet. If desired for improved accuracy, enable the online Z Calculation and configure the Critical Temperature and Pressure of the process gas.
- **Flow**
  - Compensated Signal (Standard Algorithm)**  
Enable this selection if the flow input is calibrated as mass or normal/standard volumetric flow. Due to shorter time constants and measurement accuracy, flow element differential pressure is the preferred flow input, in which case this item should be left unchecked.
  - Differential Pressure? (Standard Algorithm)**  
If the flow input is differential pressure across the flow element (the previous Compensated Signal item is unchecked), enable this selection to perform square-root extraction in the control (preferred). If square-root extraction is performed by the transmitter (not preferred), uncheck this item.
  - Flow (Mass or Normal) (Standard Algorithm)**  
Select Mass or Normal/Standard Volumetric to correspond with the flow transmitter calibration, if other than differential pressure. This selection also determines the units for calculated sensor and compressor stage flows displayed on the HMI.
  - Flow Constant (Standard Algorithm)**  
If the flow input is differential pressure across the flow element (the previous Compensated Signal item is unchecked), this value indicates the Standard Algorithm's flow calculation constant corresponding to the flow element sizing data. It is calculated by the HMI/CCT's Standard Mapper Tool and is shown here for verification only. See Operating Point Calculations in Chapter 2 for a detailed description of this constant. While the HMI/CCT will automatically calculate the constant, it can be verified and adjusted, if necessary, on the operating Map screen.
  - Corrected Flow Constant (Universal Algorithm)**  
This value indicates the Universal Algorithm Corrected Flow Constant. It is calculated by the HMI/CCT's Universal Mapper Tool and is shown here for verification only. See Operating Point Calculations in Chapter 2 for a description of this constant. While the HMI/CCT will automatically calculate the constant, it can be verified and adjusted, if necessary, on the operating Map screen.

### **Polytropic Exponent at the Reference Condition (Universal Algorithm)**

This value indicates the reference condition polytropic exponent used by the Universal Algorithm. It is calculated by the HMI/CCT's Universal Mapper Tool and is shown here for verification only. See Operating Point Calculations in Chapter 2 for a description of this constant. While the HMI/CCT will automatically calculate the constant, it can be verified and adjusted, if necessary, on the operating Map screen.

- **S\_PV**

Tune the Base Control Margin as a percentage of flow above surge. This value, typically eight (8) to ten (10) percent, determines the location of the Surge Control Line to the right of the Surge Limit Line.

- **Anti-surge Valve**

#### **Invert Output (Fail Open)**

Enable this selection if the anti-surge valve is fail-open (air to close).

#### **Auto Decay Valve Rate**

Tune this value to the rate, in percent per second, used by the various control responses (BOOST, Surge Recovery, Sequencing, Remote Manual Positioning, Decoupling) to ramp the anti-surge valve closed.

#### **Valve Freeze Enable**

Enable this function to clamp the anti-surge valve output at a constant value, instead of constantly, and unnecessarily, modulating in response to small, minor process swings. This is intended to decrease unnecessary wear on the anti-surge valve and to help stabilize minor process swings.

#### **Freeze Delay Time**

Tune this value to the delay, in seconds, used by the Freeze routine before clamping valve demand.

#### **HSS Aux #1 Enable**

Enable this function to configure an auxiliary analog input to the anti-surge control HSS (High Signal Select) bus for automatic anti-surge valve positioning. The input must be configured, either from the upstream device, or at the control's input, as percent open (within 0-100% range).

#### **HSS Aux #1 Filter**

Tune this value to the delay, in seconds, for a first-order lag filter on the auxiliary input. Tune to 0.0 for no filtering.

#### **HSS Aux #2 Enable**

Enable this function to configure an auxiliary analog input to the anti-surge control HSS (High Signal Select) bus for automatic anti-surge valve positioning. The input must be configured, either from the upstream device, or at the control's input, as percent open (within 0-100% range).

#### **HSS Aux #2 Filter**

Tune this value to the delay, in seconds, for a first-order lag filter on the auxiliary input. Tune to 0.0 for no filtering.

#### **Overstroke Enable**

Enable this function to positively seat the anti-surge valve in the full-open and full-closed positions.

#### **Overstroke Amount Open**

Tune this value to the overstroke amount for the open position. When the valve demand reaches 99.8%, this overstroke percentage is added to the output, forcing the valve fully open with a demand greater than 100%.

#### **Overstroke Amount Closed**

Tune this value to the overstroke amount for the closed position. When the valve demand reaches 0.2%, this overstroke percentage is subtracted from the output, forcing the valve fully closed with a demand less than 0%.



- **Manual**

- **Remote Enable**

- Enable this selection to use a configurable analog input as a remote valve demand when in Full Manual or Manual with Backup Modes.

- **Valve Rate**

- Tune this value to the rate, in percent per second, used by the Manual controls to ramp the anti-surge valve open and closed. This rate is also used when the valve is ramped open during a turbine controlled shutdown.

- **Transmitter Fail Additional Amount**

- Tune this value to the valve opening position, in percent, that is added to the current position when a signal failure (flow, or others if configured) occurs and the control reverts to Full Manual Mode.

- **Shutdown Positioning Enable**

- Enable this selection to automatically position the anti-surge valve in the shutdown position if a shutdown is received when operating in Full Manual or Manual with Backup Modes.

## Compressor Discretes Screen

The selections on this screen configure the discrete inputs and outputs related to the compressor control.

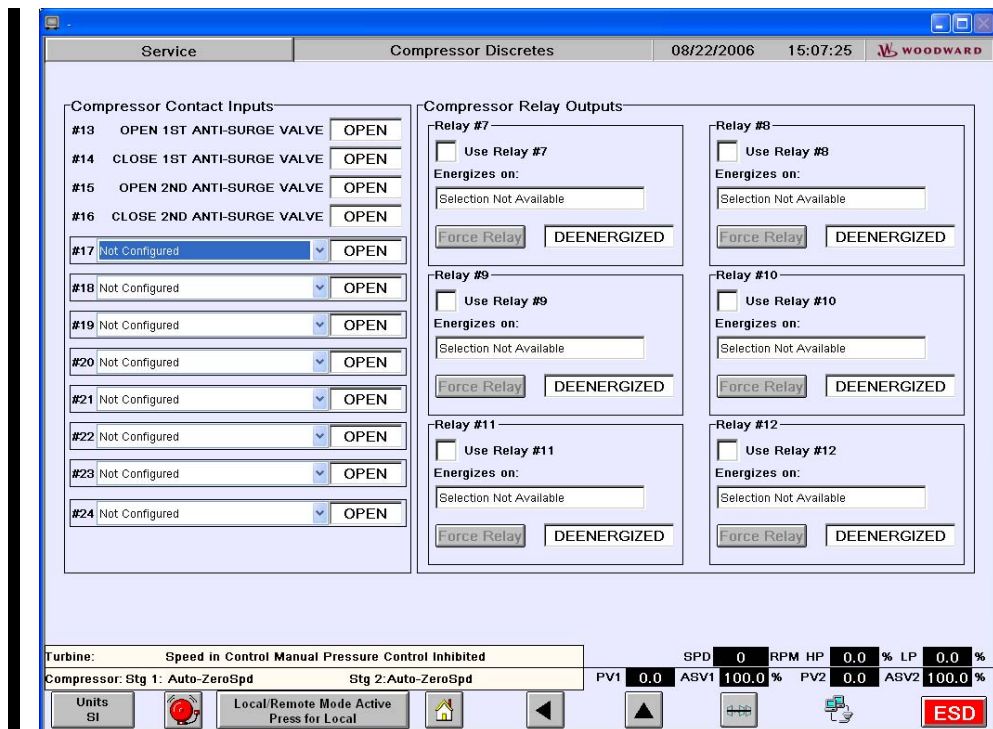

Figure 4-9. Compressor Discretes Configuration Screen

- **Compressor Contact Inputs**

- Four (4) discrete inputs are fixed for open and close commands to each of the two possible anti-surge valves.

- There are eight (8) configurable discrete inputs available for the compressor control. Select the appropriate function from the list box—Each function can only be assigned once.

- The status (Open/Closed) of each discrete input is also displayed.

- Compressor Relay Outputs**  
 There are six (6) configurable discrete outputs available from the compressor control. Enable the use of the relay drivers as needed and select the appropriate function from the list box.

For each output, the current status (Energized/De-energized) is displayed. For maintenance and testing purposes, the outputs can be forced manually—Select the Force Relay button to open a pop-up, shown in Figure 4-10, that allows momentary and sustained energizing of the output for testing.

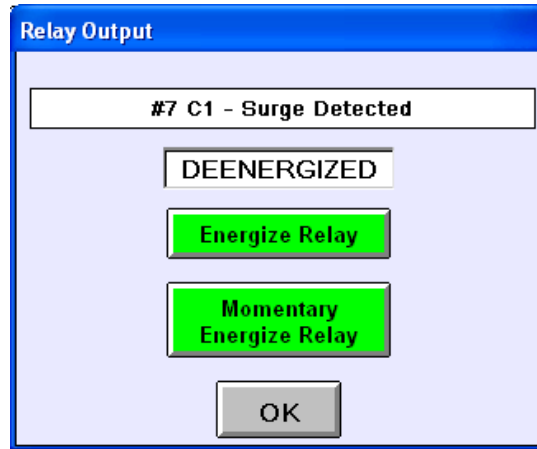

Figure 4-10. Discrete Output Forcing Pop-Up

### Compressor Analogs Screen

The selections on this screen configure the analog inputs and outputs related to the compressor control.

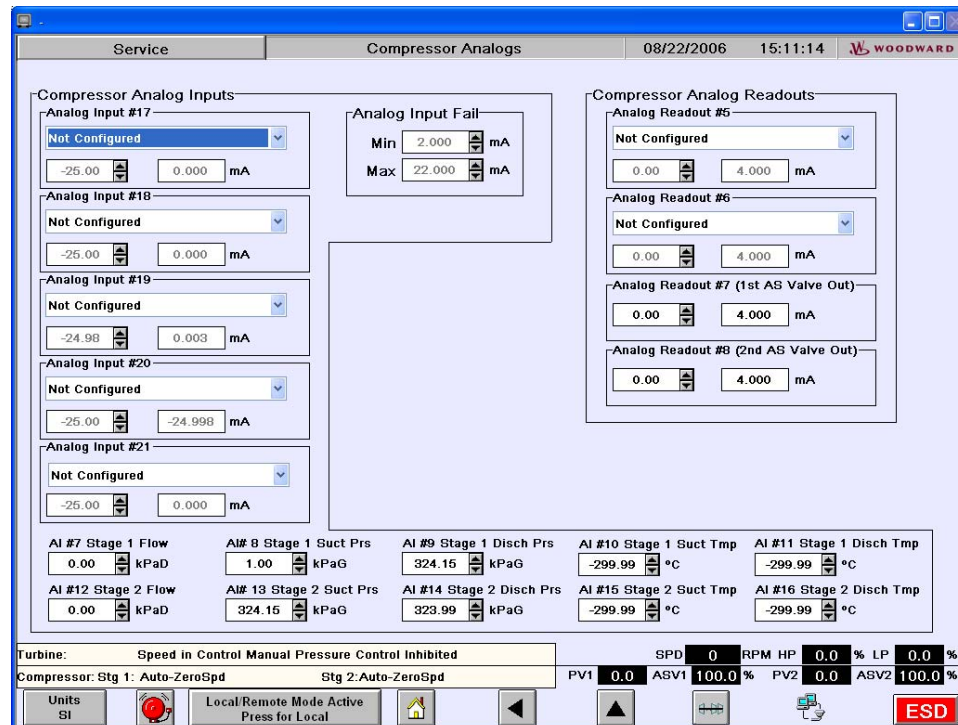

Figure 4-11. Compressor Analogs Configuration Screen

- **Analog Inputs**

There are five (5) configurable analog inputs, numbers seventeen (17) through twenty-one (21), available for the compressor control. Select the appropriate function from the list box—Each function can only be assigned once. The value of each input signal, in both engineering units and milliamps, is also displayed.

The min and max current levels for Analog Input Failure can also be adjusted from their default 2–22 mA configuration.

Each analog input features a calibration pop-up, shown in Figure 4-12, to allow configuration of the 4–20 mA range values, offset and gain (zero and span) adjustments, and a filter time constant (not required for primary compressor inputs #7 – #16). The current engineering unit value is also displayed. If Redundant Flow or Pressure is assigned as a configurable analog input, its engineering units must match that of the primary input (kPa, kg/hr, m<sup>3</sup>/hr). It is also strongly recommended that the 4–20 mA input range itself match the primary's. Similarly, if Flow Element Pressure or Temperature is used, its engineering units must also be SI (kPa, °C) like its compressor counterpart's. Any valve related input (HSS Auxiliary Input, Remote Manual Position, etc.) must be calibrated as 0-100% open.

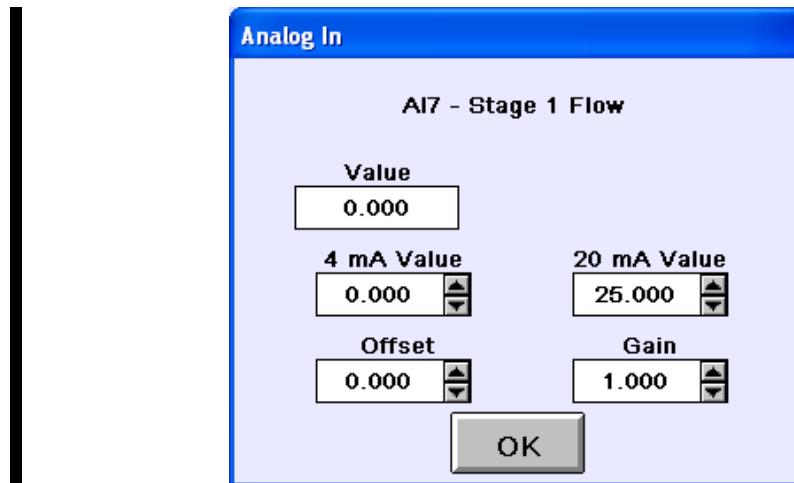

Figure 4-12. Compressor Analog Calibration Pop-Up

### **IMPORTANT**

If the alternate flow element pressure (PF) or temperature (TF) inputs are used, return to the Stage 1 I/O or Stage 2 I/O configuration screens to verify or change the Last Good Value and Default Value configuration.

Ten (10) analog inputs, numbers seven (7) through sixteen (16), are fixed for flow, suction pressure, discharge pressure, suction temperature, and discharge temperature for each of the two compressor sections. Temperature inputs are ignored for the Universal Algorithm. While the field instruments may be calibrated in any engineering unit, the 505CC-2 must receive compressor input signals in SI units of kilopascals (kPa) and degrees centigrade (°C). In addition to flow element differential pressure (kPaD), Standard Algorithm flow units may also be kilograms per hour (kg/hr) or cubic meters per hour (m<sup>3</sup>/hr), if the input was configured as “Compensated” on the I/O Configuration Screen. If the field device is calibrated in other units, simply calculate the proper SI engineering unit range when configuring the 4 mA and 20 mA values for these inputs. Calibration pop-ups are provided as described above. However, lag filter time constants are omitted as compressor input filtering is handled internally, and time constants are configurable on the I/O Configuration Screen.

- **Analog Readouts**

There are two (2) configurable analog outputs, numbers five (5) and six (6), available from the compressor control. Select the appropriate function from the list box.

Similar to the inputs, a calibration pop-up, shown in Figure 4-13, facilitates configuration of the 4–20 mA range values, offset, and gain. And, like the discrete outputs, a forcing function is provided for maintenance and testing. Select the Force button to enable forcing—The button will change from red to green. When the button is green, forcing is enabled, and the adjustment pop-up becomes available by selecting the displayed engineering unit value. Stroke the output using the new pop-up to manipulate the engineering unit value. When forcing is completed, select the Force button again to disable.



Figure 4-13. Analog Output Calibration Pop-Up

The two (2) fixed analog outputs, numbers seven (7) and eight (8), are dedicated for the anti-surge valves.

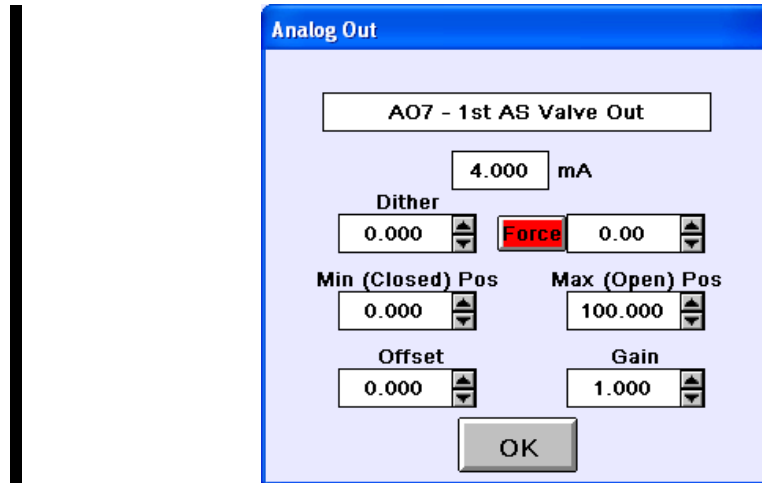

Figure 4-14. Analog Output Calibration Pop-Up

Like all other I/O, the calibration pop-up, shown in Figure 4-14, provides access to offset and gain adjustments and a forcing function to stroke the output. Though they are available, it is recommended not to adjust the Min and Max Position values. Configure dither if desired. Dither is a 12.5 Hz oscillation applied to the anti-surge valve output to help prevent “stiction” from developing in the valve and its related components. Tune this value to the oscillation’s peak amplitude, in percent valve position. If desired, 0-1% is typical, but tune to 0.0 for no dither. When active, dither should not be visible as physical movement of the valve.

### IMPORTANT

To configure a fail-open valve, valve action could be reversed by setting the Min Position Value to 100% and the Max Position Value to 0%. This would have the same effect as configuring the valve as Fail Open on the I/O Configuration Screen. However, it is recommended to use the latter method and leave the 4–20 mA range values at their defaults. If both methods are accidentally employed at the same time (Fail Open configured and mA calibration reversed), the valve will not operate as desired.

### Compressor Standard Map Tool Screen (if Standard Algorithm is configured)

The selections on this screen configure the compressor’s standard performance map into the control and calculate the flow constant, which make it one of the most important of the required configuration screens. It primarily converts the user’s compressor performance map from any unit representation into that which is required by the control, actual suction flow ( $m^3/hr$ ) versus polytropic head (N·m/kg). Data should be taken directly from the compressor performance map and API data sheet, using the rated operating point as necessary. This software tool will also calculate the required flow constant when data are entered from the flow element calculation sheet.

Figure 4-15. Standard Map Tool Data Entry Screen

In the General section, select which compressor section is being configured. Also identify the unit convention and base pressure and head units for the default map. These selections allow the user to convert a map from several common unit bases into the 505CC-2's required flow versus head implementation.

Select the flow and head axis representations that match the default map. If normal/standard flow is selected for the X-axis, enter the reference condition pressure and temperature. These are required to convert normal/standard flow to actual flow. Reference condition compressibility is assumed to be 1.0. Enter the surge limit line as five (5) X-Y coordinate pairs from the original compressor performance map. These points are typically the intersections of the constant speed lines with the surge limit line and should be entered in ascending order. Points can be duplicated if the surge line has no, or few, deflections. The control interpolates linearly between adjacent points and continues the end slopes past points one (1) and five (5).

## WARNING

Configure the Surge Limit Line data pairs in ascending order (recommended) and with positive slope (head and flow both increasing) (required). Also, verify all data before executing the mapper tool with the Calculate Map button. Executing the mapper tool with invalid data may crash the HMI/CCT application.

Depending upon the axes selections above, additional suction and discharge data are required. Enter the gas molecular weight; suction temperature, pressure, compressibility, and specific heat ratio; discharge compressibility and specific heat ratio; and compressor polytropic efficiency as prompted. All data should be taken from the compressor's predicted performance map and API data sheet.



As noted in earlier chapters, a differential type flow measurement requires configuration of a flow constant to correlate the differential pressure measured across the flow element to actual rate of flow. This constant is an aggregate of several constants, or near-constant values, in the standard flow equation. Enter the flow element beta ratio ( $\beta$ ), bore or throat diameter ( $d$ ), discharge coefficient ( $C$ ), and gas expansion factor ( $Y$ ) from the flow element calculation sheet. The latter value, but to some degree all four, will vary with process conditions and flow rate. And, flow element calculations are often made at a maximum flow condition for calibration of the flow (differential pressure) transmitter. As such, the flow element calculation sheet's data may not be relevant to normal compressor operation. If possible, maximum accuracy is achieved by selecting these "constants" that correspond to the compressor's normal operating conditions and flow rate. If, however, such data is unavailable, simply use that which is provided on the calculation sheet—Errors introduced are manageable, and the flow constant can be adjusted, or fine-tuned, at a later time.

**IMPORTANT**

**The standard flow equation for differential producing flow elements changes slightly for annubars, or averaging pitot tubes. For this type of element, substitute 0 for the beta ratio and the pipe internal diameter ( $D$ ) for bore diameter ( $d$ ).**

The Unit Converted Surge Line section displays the five surge limit line points that were entered previously, but converted into the standard SI units used by the 505CC-2. Similarly, intermediate calculation results are displayed in the Derived Values section. All of this data, those entered by the user and the intermediate displayed values, are used by the Standard Mapper Tool to calculate the unit specific surge limit line that will be downloaded to the 505CC-2 control.

Use the Save Data and Load Data buttons to save and load the map data to and from a file, if desired. The default path for saved data is *C:/Program Files/Advantech Studio v5.2/Projects/505CC-2/WGFiles*. Verify that all data is correct, and select the Calculate Map button to run the Standard Mapper Tool and view its output.

As shown in Figure 4-16, the compressor performance map is displayed in graphical form. If configured, the base control margin (I/O Configuration screen) and the BOOST, or backup line, margin (Open Loop Configuration screen) are used to generate the respective lines on the map. The map's axes limits are defaulted to the zero-flow zero-head origin, 175% of the surge line's maximum flow, and 110% of the surge line's maximum head. These X- and Y-axis minimum and maximum limits may be adjusted to customize the appearance of the map. The same map is used on the dynamic, operating map screen, so it may be desirable to adjust the axes limits to match the original performance map from the manufacturer. If the limits are modified, select the Update Plot button to redraw the map with the new limits.

As mentioned previously, the flow constant ( $K$ ) may also be adjusted. This may be necessary if the flow element data was unknown, or if its calibration point was far from normal compressor operation.

Once the map is adjusted and the data is verified for accuracy, select the Save Map button to write the pertinent values to the 505CC-2 control.



Figure 4-16. Standard Map Output Screen

### Compressor Universal Map Tool Screen (if Universal Algorithm is configured)

The selections on this screen convert the compressor's standard performance map into the "Universal" invariant coordinate system of corrected flow (m<sup>3</sup>/hr) versus pressure ratio. It also calculates the corrected flow constant and polytropic exponent, which make it one of the most important of the required configuration screens. Data should be taken directly from the compressor performance map and API data sheet, using the rated operating point as necessary.

In the General section, select which compressor section is being configured. Also identify the unit convention and base pressure and head units for the default map. These selections allow the user to convert a map from several common unit bases into the 505CC-2's required flow versus pressure ratio implementation.



Service: Universal Map Data 08/22/2006 15:15:59 WOODWARD

**General**  
 Select Stage:  Stage 1  Stage 2  
 Select Units:  SI  Imperial  
 Select Pressure Units:  kPaA  AtmA  kg/cm<sup>2</sup>A  barA  
 Select Head Unit:  N-m/kg  kg-m/kg

**Flow Element**  
 Flow Element Type: Concentric, Square-Edged Orifice w/ Flange Taps  
 Location: Suction  
 Pipe Internal Diameter (D) (At Flow Element): 742.95 mm  
 Beta Ratio (β): 0.349419

**Reference Condition Process Data**  
 Molecular Weight (MW): 28.05  
 Ratio of Specific Heats (k): 1.4 (at FE)  
 Suction Pressure (P<sub>s</sub>): 425.6 kPa  
 Suction Temperature (T<sub>s</sub>): -74.8 °C  
 Suction Compressibility (Z<sub>s</sub>): .907  
 Discharge Pressure (P<sub>d</sub>): 1058 kPa  
 Discharge Temperature (T<sub>d</sub>): -19.8 °C  
 Discharge Compressibility (Z<sub>d</sub>): .891

**Original Surge Line**  
 X-Axis: Actual Suction Flow Y-Axis: Polytropic Head  

Data Point	X-Axis (Am <sup>3</sup> /h)	Y-Axis (N-m/kg)
Data Point 1:	12000	30498.7
Data Point 2:	13900	40893.7
Data Point 3:	17600	52759.8
Data Point 4:	21600	65312.3
Data Point 5:	23700	71980.8

Save Data Load Data Calculate Map

Turbine: Speed in Control Manual Pressure Control Inhibited SPD: 0 RPM HP: 0.0 % LP: 0.0 %  
 Compressor: Stg 1: Auto-ZeroSpd Stg 2: Auto-ZeroSpd PV1: 0.0 ASV1: 100.0 % PV2: 0.0 ASV2: 100.0 %  
 Units: SI Local/Remote Mode Active Press for Local ESD

Figure 4-17. Universal Map Tool Data Entry Screen

As noted in earlier chapters, a differential type flow measurement requires configuration of a flow constant to correlate the differential pressure measured across the flow element to actual rate of flow. This constant is an aggregate of several constants, or near-constant values, in the standard flow equation. In the Flow Element section, select the applicable flow element type from the list. If the correct type is not shown, select Other. Also select the flow element location as Suction or Discharge. Depending upon which element type is selected, additional sizing data must be entered. Enter the pipe internal diameter (D), flow element beta ratio ( $\beta$ ), and discharge coefficient (C), as prompted, from the flow element calculation sheet. To some degree, all of these values will vary with process conditions and flow rate. And, flow element calculations are often made at a maximum flow condition for calibration of the flow (differential pressure) transmitter. As such, the flow element calculation sheet's data may not be relevant to normal compressor operation. If possible, maximum accuracy is achieved by selecting these "constants" that correspond to the compressor's normal operating conditions and flow rate. If, however, such data is unavailable, simply use that which is provided on the calculation sheet—Errors introduced are manageable, and the corrected flow constant can be adjusted, or fine-tuned, at a later time.

Select the flow and head axis representations that match the default map. If normal/standard flow is selected for the X-axis, enter the reference condition pressure and temperature. These are required to convert normal/standard flow to actual flow. Reference condition compressibility is assumed to be 1.0. Enter the surge limit line as five (5) X-Y coordinate pairs from the original compressor performance map. These points are typically the intersections of the constant speed lines with the surge limit line and should be entered in ascending order. Points can be duplicated if the surge line has no, or few, deflections. The control interpolates linearly between adjacent points and continues the end slopes past points one (1) and five (5).

Additional suction and discharge data are required to properly calculate the corrected flow constant and polytropic exponent. Enter the gas molecular weight; specific heat ratio at the flow element; suction pressure, temperature, and compressibility; and discharge pressure, temperature, and compressibility as prompted. All data should be taken from the compressor's predicted performance map and API data sheet for the reference or rated operating point.

<b>WARNING</b>	<p>Configure the Surge Limit Line data pairs in ascending order (recommended) and with positive slope (head and flow both increasing) (required). The Reference Condition Data must also fall within the Surge Limit Line's head envelope (Point #1 Head &lt; Rated Head &lt; Point #5 Head). Also, verify all data before executing the mapper tool with the Calculate Map button. Executing the mapper tool with invalid data may crash the HMI/CCT application.</p>
----------------	--

The Unit Converted Surge Line section displays the five surge limit line points that were entered previously, but converted into the standard SI units used by the 505CC-2. All of this data is used by the Universal Mapper Tool to calculate the unit specific surge limit line that will be downloaded to the 505CC-2 control.

Use the Save Data and Load Data buttons to save and load the map data to and from a file, if desired. The default path for saved data is *C:/Program Files/Advantech Studio v5.2/Projects/505CC-2/WGFiles*. Verify that all data is correct, and select the Calculate Map button to run the Universal Mapper Tool and view its output.



Figure 4-18. Universal Map Output Screen

As shown in Figure 4-18, the compressor performance map is displayed in graphical form. If configured, the base control margin (I/O Configuration screen) and the BOOST, or backup line, margin (Open Loop Configuration screen) are used to generate the respective lines on the map. The map's axes limits are defaulted to the zero-flow unity-pressure ratio origin, 175% of the surge line's maximum flow, and 110% of the surge line's maximum pressure ratio. These X- and Y-axis minimum and maximum limits may be adjusted to customize the appearance of the map. The same map is used on the dynamic, operating map screen, so it may be desirable to adjust the axes limits to match the original performance map from the manufacturer. If the limits are modified, select the Update Plot button to redraw the map with the new limits.

As mentioned previously, the corrected flow constant (K) may also be adjusted. However, it is accurate at rated compressor operating conditions only—the calculated “corrected” flow will deviate from actual flow as the compressor operation deviates from the reference condition. Therefore, there is no reliable way to relate “corrected” flow to any other measured flow. Provided that the flow element and compressor reference condition data used by the Universal Mapper Tool are accurate, there should be no need to adjust the calculated flow constant or polytropic exponent.

Once the map is adjusted and the data is verified for accuracy, select the Save Map button to write the pertinent values to the 505CC-2 control.

## Loop Period Test Procedure

The system response time for the 505CC-2 is measured as the Loop Period. This is the time from making a change in the anti-surge valve until the change is detected in the S\_PV calculation. The detected change is most often determined to be 90% of the total change. So if S\_PV changes from 120% to 130%, the loop period is the time from the change of valve demand until S\_PV indicates 129%.

Test each anti-surge valve's loop period by following this procedure. If operators are uncomfortable with doing this complete test, just do a single valve step and record the time.

1. At the Stage I/O configuration screen, increase the Manual Valve Rate to some large value, 50 %/s for example. This will better simulate a step change in valve position as opposed to a slower ramp.
2. In Manual with Backup or Full Manual Mode, use the preset function to complete each of the following steps from 0%.
  - Open the anti-surge valve to 5%. Determine the time it takes from opening the valve to seeing the flow signal stabilize.
  - Open the anti-surge valve to 10%. Determine the time it takes from opening the valve to seeing the flow signal stabilize.
  - Open the anti-surge valve to 15%. Determine the time it takes from opening the valve to seeing the flow signal stabilize.
3. Put the control back into Automatic Mode and return the Manual Valve Rate to its original setting.

After this test is completed compare the loop period times. If the numbers are the same or similar (i.e. 5,6,7) then the system is lag time limited and Pre-pack will speed up open-loop step response. Select the lower time or an average to configure the Loop Period on the Open Loop Configuration Screen. If the numbers are proportional (i.e. 3,6,9) then the system is rate limited (or valve limited) and the Pre-pack function will not help. In this case, select the lower time to configure the Loop Period on the Open Loop Configuration Screen. If only step 1 of the test is done and the loop period is greater than 10 seconds, enable the Pre-pack function.

If the test was unsuccessful, then possibly the compressor was choked or flow limited. To correct this problem, reduce the flow through the compressor and repeat the test.

The configured Loop Period time is used by the control in calculating the Rate PID setpoint, in determining how long to apply the BOOST and Surge Recovery routines, and in determining how long to wait for the system to respond to these actions before resuming surge detection. In the cases of the open-loop responses, the shorter the configured loop period time, the more conservative or aggressive the control response, but the more likely it is for unnecessary or excessive recycling. But, for the Rate PID controller, a shorter loop period actually “detunes” the control by increasing the allowable operating point rate of movement (Rate PID setpoint). In other words, adjusting the Loop Period time may help one control routine but hurt another. Since a conservative or aggressive strategy is generally preferred to ultimately protect the compressor, even at the expense of excessive but temporary recycling, it is usually best to err on the side of a shorter Loop Period time if the test described above does not produce a definitive value. In this case however, the Rate PID Setpoint, if enabled, should be reduced to compensate for the shorter Loop Period.

## Dynamics Adjustments

The Anti-Surge, Rate Control, Suction Pressure Override, and Discharge Pressure Override controls are PID controllers. The response of each control loop can be adjusted by configuring the proportional gain, integral gain (stability), and SDR (speed derivative ratio) at the Stage Closed Loop configuration screen. These are the adjustable and interacting parameters used to match the response of the control loop with the response of the system. They correspond to the P (proportional), I (integral), and D (derivative) terms, and are displayed by the 505CC-2 as follows:

- P = Prop Gain (% output per unit error)
- I = Int Gain (repeats per minute)
- D = Deriv Ratio

Refer to the sections below for general tuning theory and procedures. See Chapter 5 for specific features of the 505CC-2's compressor control tuning screens.

### Tuning P & I Gains

Proportional gain must be tuned to best respond to a system transient or step change. If system response is not known, a typical starting value is 5%. If proportional gain is set too high the control will appear to be overly sensitive, and may oscillate with a cycle time of less than 1 second.

Integral gain must be tuned for best control at steady state. If system response is not known a typical starting value is 0.5%. If the integral gain is set too high the control may hunt or oscillate at cycles times of over 1 second.

For best response, the proportional gain and integral gain should be as high as possible. To obtain a faster transient response, slowly increase the proportional gain setting until the actuator output begins to oscillate or waver. Then adjust the integral gain as necessary to stabilize the output. If stability cannot be obtained with the integral gain adjustment, reduce the proportional gain setting.

A well-tuned system, when given a step change, should slightly overshoot the control point, and then come into control.

A PID control loop's gain is a combination of all the gains in the loop. The loop's total gain includes actuator gain, valve gain, valve linkage gain, transducer gain, and the 505CC-2's adjustable gains. If the accumulated mechanical gain (actuators, valves, valve linkage, etc.) is very high, the 505CC-2's adjustable gains must be very low to result in a system gain that affords stability.

In cases where a small change in the 505CC-2's output results in a large load change (high mechanical gain) it may not be possible to take the 505CC-2's gains low enough to reach stable operation. In those cases the mechanical interface (actuator, linkage, servo, valve rack) design and/or calibration should be reviewed and changed to achieve a gain such that 0-100% 505CC-2 output corresponds to 0-100% valve travel.

## Tuning Derivative

The value of the Derivative Ratio (DR) term can range from 0.01 to 100. In order to simplify adjustment of the dynamics, adjusting the integral gain value sets both the I and D terms of the PID controller. The DR term establishes the degree of effect the integral gain value has on the "D" term, and changes the configuration of a controller from input rate sensitive (input dominant) to feedback rate sensitive (feedback dominant) and vice versa.

Another possible use of the DR adjustment is to reconfigure the controller from a PID to a PI controller. This is done by adjusting the DR term to its upper or lower limits, depending on whether an input or feedback dominant controller is desired.

- A DR setting of 1 to 100 selects feedback dominant mode.
- A DR setting of .01 to 1 selects input dominant mode.
- A DR setting of .01 or 100 selects a PI only controller, input and feedback dominant respectively.

The change from one of these configurations to the other may have no effect during normal operation; however, it can cause great differences in response when coming into control. (i.e. at start-up, during a load change, or during transfer of control from another channel).

An input dominant controller is more sensitive to the change-of-rate of its input, and can therefore prevent overshoot of the set-point better than a feedback dominant controller. Although this response is desirable during a start-up or load rejections, it can cause excessive control motions in some systems where a smooth transition response is desired and where noise is present.

A controller configured as feedback dominant is more sensitive to the change-of-rate of its feedback (the HSS bus). A feedback dominant controller has the ability to limit the rate of change of the HSS bus when a controller is near its set-point but is not yet in control. This limiting of the HSS bus allows a feedback dominant controller to make smoother control transitions than an input dominant controller. However, the feedback dominant controller is slightly slower to respond to the initial input disturbance. Because it is more forgiving (easier to tune) and less sensitive to signal noise, most PIDs will be configured as feedback dominant ( $1 < DR < 100$ ).

## Tuning Example

If the system is unstable, first verify whether or not the control is the cause. Place the control in Manual with Backup Mode and open the valve until the manual ramp has control of the actuator output. If the system continues to oscillate when Manual is in control of the valve, the system instability is caused by an external device/function. If the controller is causing the oscillation, time the oscillation cycle. Generally, if the system's oscillation cycle time is less than 1 second, reduce the proportional gain term. Conversely, if the system's oscillation cycle time is greater than 1 second, reduce the integral gain term (proportional gain may need to be increased as well).

On an initial start-up with the 505CC-2, all PID dynamic gain terms will require adjustment to match the respective PID's response to that of its control loop. There are multiple dynamic tuning methods available that can be used with the 505CC-2's PIDs to assist in determining the gain terms that provide optimum control loop response times (Ziegler Nichols, etc.). The following method is a simplified version of other tuning methods, and can be used to achieve PID gain values that are close to optimum:

1. Place the control in Automatic Mode
2. Increase the Derivative Ratio (DR) to 100.00 (This is the default setting).
3. Reduce integral gain to minimum.
4. Increase the proportional gain until the system just starts to oscillate.
5. Record the system gain (G) as the current proportional gain value and time the oscillation period (T) in seconds.
6. Set the dynamics as follows:
  - For PID control set the proportional gain= $0.60 * G$ ; integral gain= $20/T$ ; SDR=5
  - For PI control set the proportional gain= $0.45 * G$ ; integral gain= $12/T$ ; SDR=100

This method of tuning will result in acceptable gain settings. They can be fine-tuned from this point. Figure 4-19 shows the typical response to a load change when the dynamics are optimally adjusted.

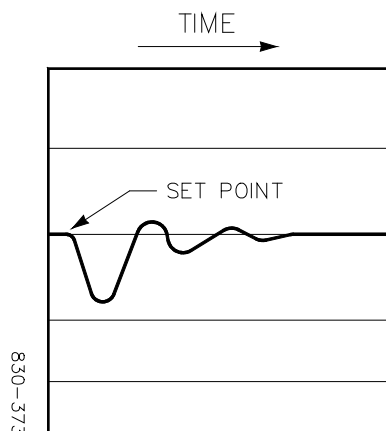

Figure 4-19. Typical Response to Load Change



# Chapter 5.

## Compressor Operation Overview

### Introduction

Operational requirements of compressor trains are as varied as the processes in which they operate. This chapter is intended to provide an overview of compressor operation with respect to the 505CC-2's functionality only. For more complete, process-specific compressor or plant operating instructions, contact the plant-equipment manufacturer.

### Compressor Operation

The HMI/CCT's common screen footer displays status messages and pertinent data for the compressor (both stages if applicable) at the bottom of every screen. To the right side of the footer, the S\_PV process variable and anti-surge valve demand are shown. The former will blink red when S\_PV falls below 98% while the unit is online as an immediate visual indication that the compressor is operating to the left of the Surge Control Line. To the left side of the footer is a status message that will indicate the compressor's current control mode (Auto, Manual with Backup, Full Manual) and controlling function.

Once configured, the 505CC-2 provides fully automatic control of the compressor's anti-surge valve(s). During normal operation, there is generally little or no intervention required by an operator. The compressor operating screens, available from the Main Menu shown in Figure 5-1, provide access to all pertinent data used by the control to position the anti-surge valves. The sections below describe typical start-up, online operation, and shutdown scenarios, as well as how to use the available screens and data to interpret compressor operation and intervene as required.

#### Start-up

When shutdown and at zero speed (0 rpm), the unit is off-line, and the 505CC-2 maintains the compressor anti-surge valve at the "Zero Speed Position." Typical compressor start-ups are on full recycle during a steam turbine warm-up, which may last several hours. As steam is initially admitted to the turbine and speed increases past the compressor's configured "Zero Speed" setpoint, the control ramps the anti-surge valve to the "Start Position." This start sequence may also be triggered by a configurable discrete input or Modbus command.

The control will remain off-line, in the start sequence, with the valve at the "Start Position" until an on-line condition is triggered. All enabled on-line triggers (speed, suction pressure, discharge pressure, flow, auxiliary input) must be satisfied to go on-line and transfer from sequencing to automatic control. If a shutdown (i.e. turbine trip, ESD, configurable discrete input, Modbus command) is received at any time during start-up, the control will sequence the valve to the "Shutdown Position" and await a restart (configurable discrete input, Modbus command) or slow to zero speed.

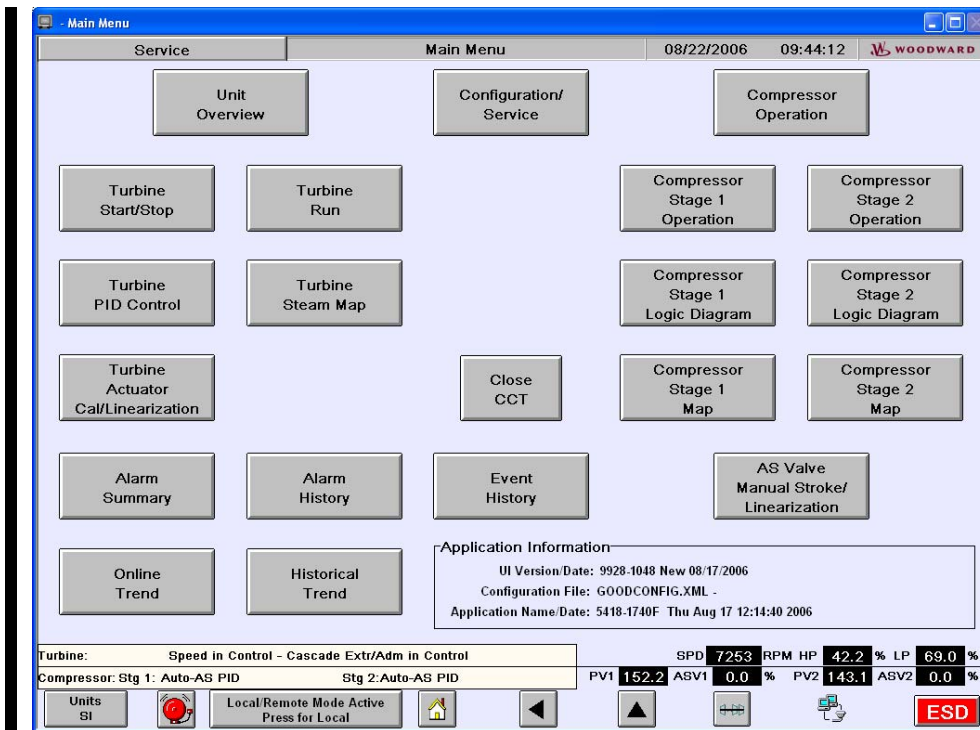

Figure 5-1. Main Menu Screen

## On-Line / Normal Operation

After the unit goes on-line, as determined by the 505CC-2's on-line detection routines, control of the anti-surge valve is transferred from sequence positioning to full automatic control. Provided that load is sufficient and  $S\_PV$  is greater than 100, the Anti-Surge PID control will slowly close the anti-surge valve. The 505CC-2 will monitor operation and position the valve as determined by the various control routines:

- Anti-Surge PID
- Rate PID
- BOOST / Valve Step Opening
- Surge Recovery
- Surge Minimum Position
- Decoupling
- Suction Pressure Override
- Discharge Pressure Override
- Auxiliary Control Inputs (2)
- Manual Control (Manual with Backup, Full Manual)

Removal of an on-line trigger (speed, suction pressure, discharge pressure, flow, auxiliary input) will revert control to the start sequence and ramp the valve to the "Start Position." The control will remain as such until the on-line trigger is restored.

If a shutdown (turbine trip, ESD, configurable discrete input, Modbus command) is received, the control will sequence the valve to the "Shutdown Position" and await a restart (configurable discrete input, Modbus command) or slow to zero speed.



## Emergency Shutdown

When a shutdown is received, the anti-surge valve is immediately moved to the configured “Shutdown Position.” The shutdown sequence remains active until the unit slows below the configured “Zero Speed” setpoint, at which time the valve is ramped to the configured “Zero Speed Position.” If, however, before slowing to zero speed, the shutdown is cleared and reset and a restart commanded, sequence control takes over as described previously for a start-up—The anti-surge valve(s) will revert to the configured “Start Position” until an online condition is detected, at which time the 505CC-2 transfers to automatic Anti-Surge control.

## Controlled Shutdown

A controlled shutdown, or normal stop, is initiated through the turbine control and is designed to slowly ramp unit speed down in a controlled manner. This condition will not cause the compressor’s Anti-Surge Valve(s) to immediately trip to the “Shutdown Position.” Rather, the automatic Anti-Surge routines remain in control of the valve(s) until an online detection trigger, described previously, is released, at which time the Anti-Surge Valve(s) is ramped to the configured “Shutdown Position” at the configured “Manual Valve Rate.”

### **WARNING**

**Consideration should be given to the relationship of the Online Detection trigger setpoints, the Manual Valve Rate, and the turbine’s Controlled Shutdown Rates. As the unit slows during a controlled shutdown, compressor flow will likely become unstable, possibly leading to surge if the anti-surge valve does not open quickly enough. The combination of a slow to moderate speed ramp, moderate to fast anti-surge valve rate, and higher online detection trigger is recommended.**

The controlled shutdown sequence remains active until the unit slows below the configured “Zero Speed” setpoint, at which time the valve is ramped to the configured “Zero Speed Position.” If, however, before slowing to zero speed, the controlled shutdown is aborted, sequence control takes over as described previously for a start-up—The Anti-Surge Valve(s) will revert to the configured “Start Position” until an online condition is detected, at which time the 505CC-2 transfers to automatic Anti-Surge control.

## 505CC-2 Compressor Operating Screens

Depending on the compressor configuration as single or dual stage (one or two sections), several compressor operating screens are available in the HMI/CCT.

## Compressor Operation Screen (Dual Stage only)

This screen, shown in Figure 5-2, provides all relevant data for both compressor sections in a tabular format, without graphics. Information presented includes all filtered input values, control values (inputs after filtering and failure routines), surge capture, calculated performance data, and control outputs. Messages are displayed to indicate the routine and sequence that are in control. Control mode (Auto, Manual with Backup, Full Manual) selections are also available. This screen is available only for two-stage configurations and is intended to provide a single screen for operation of the entire compressor train. Reference the following screen descriptions for details on the data and controls presented.

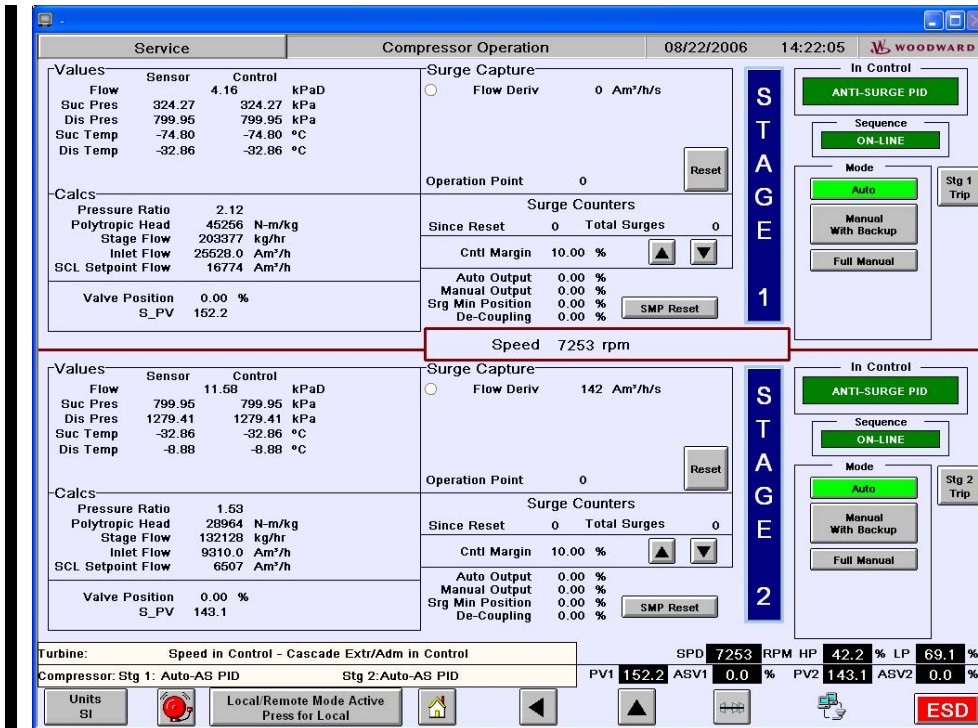

Figure 5-2. Compressor Operation Screen

## Compressor Stage 1 Operation Screen (same for Stage 2)

The primary operating screen for an individual compressor section is shown in Figure 5-3. The compressor and field instruments are displayed graphically at the top of the screen. The instrument boxes indicate the filtered input values in engineering units. The turbine and compressor body schematics are outlined in either blue or white. The latter indicates which piece of equipment is monitored by the current screen. Selecting another piece of equipment, outlined in blue, will jump to that equipment's operating screen.

**Stage Trip** The Stage Trip button provides an immediate method of placing the compressor on full recycle, instead of ramping opening the anti-surge valve in either of the Manual control modes, which could take several seconds. In other words, it initiates a compressor shutdown, without affecting the turbine control. However, Cascade Control, if enabled, will be inhibited. This might be useful in the event of significant downstream upsets, to prevent the upset from cascading back to the turbine. When the compressor is in its shutdown sequence, the button acts to put the unit back online in automatic control.

**Stage Online**

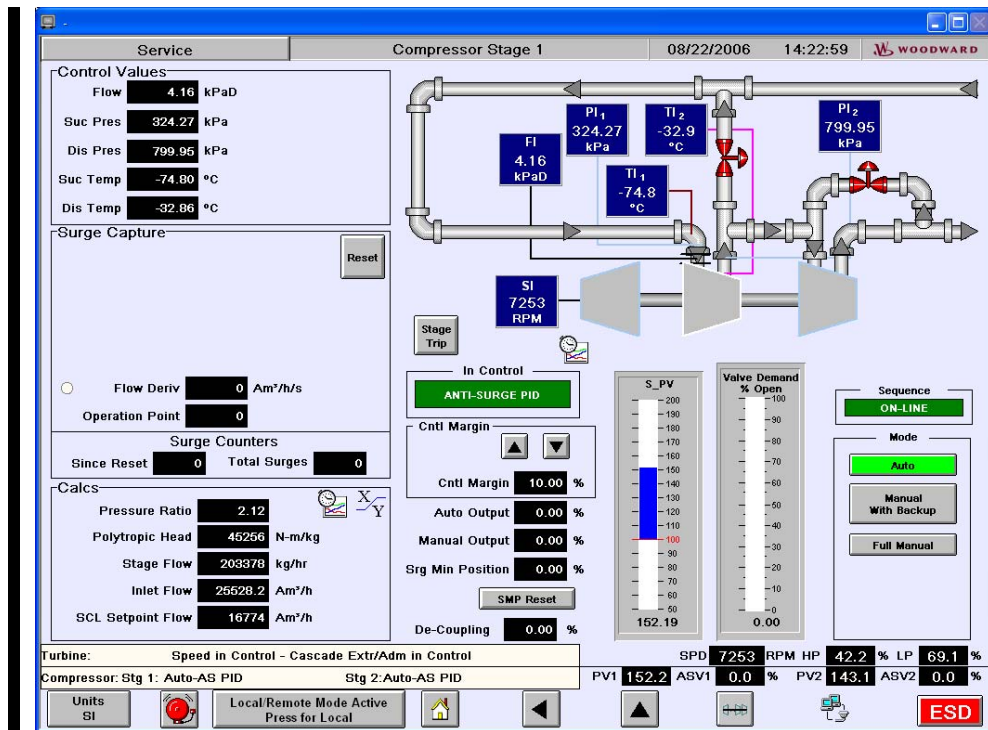

Figure 5-3. Compressor Stage Operation Screen

The “In Control” status message will indicate which of the 505CC-2’s control routines listed below is positioning the anti-surge valve at a given time.

- Anti-Surge PID
- Rate PID
- BOOST / Valve Step Opening
- Surge Recovery / Surge Minimum Position
- Suction Pressure Override
- Discharge Pressure Override
- Auxiliary Control Input #1
- Auxiliary Control Input #2
- Adjacent Stage Controller (for Dual Stage, Single-Valve configurations)
- Manual with Backup
- Full Manual
- Sequence Positioning
- Deactivation Routine

The current control margin is displayed with adjustment buttons to allow increasing and decreasing the value. The value cannot be decreased below the Base Control Margin configured on the I/O Configuration Screen.

Control demands are indicated for Auto, Manual, Surge Minimum Position (SMP), and Decoupling routines. If enabled, SMP is indicated when active—

Select the SMP Reset button to reset SMP and allow the anti-surge valve to close after a surge event.

Two bar graphs provide visual indication of S\_PV and valve demand. If enabled, the Valve Freeze function is indicated above the valve demand bar graph when active.

The “Sequence” status message will indicate which sequence the 505CC-2 is in at a given time.

- On-Line
- Off-Line – Start
- Off-Line – Purge
- Off-Line – Zero Speed
- Off-Line – Emergency Shutdown
- Off-Line – Controlled Shutdown

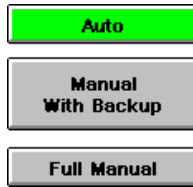

Auto/Manual switching is available with the buttons provided. The active control mode is indicated by a highlighted button. In either Manual control mode, adjustment buttons are provided to manually open or close the Anti-Surge Valve. The manual valve demand may also be entered directly as an analog value.

## IMPORTANT

The Auto/Manual mode buttons operate on a command/feedback principle. When selected, they command the 505CC-2 to the appropriate mode, but they await feedback before changing colors. Communications errors or timing problems can sometimes result in a feedback mismatch, indicated by a white colored button that appears “stuck in transition.” To clear this situation and resynchronize the buttons, reselect the original mode button. Then attempt the mode switch again.

To the left, control values (inputs after filtering and failure routines) are displayed with indicators if last good values, default values, or the Fail to Manual function are active. The surge capture is displayed below, including indicators of which routines detected the surge. The surge counter and capture values can be reset, but the Total Surges counter will remain.



To the bottom left, calculated performance values are displayed with a link to a trend page. Similar buttons elsewhere on the screen will jump to trend screens of other pertinent data. Refer to Volume 1 of this manual for more information about trend screens.



Select the X-Y Plot button to jump to the Operating Map Screen.

## Compressor Stage 1 Logic Diagram Screen (same for Stage 2)

The Logic Diagram Screen, shown in Figure 5-4, provides a flow diagram view of the 505CC-2’s compressor control functionality. It is particularly useful in illustrating the HSS bus operation. Inputs are shown to the upper left of the diagram. If enabled and active, input failure backup strategies are indicated in the respective box. The In Control and Sequence messages are duplicated to the upper right.

All control functions are shown with their individual demands to the HSS. The active function is highlighted in green. Any routine that is not configured is shown disabled in gray. Downstream logic shows the addition of the decoupling demand, if enabled, and the Full Manual mode switch, which bypasses the HSS.

Select one of the four PID amplifier symbols, outlined in blue, to jump to a tuning screen for that loop. The dynamics tuning screens are detailed below. Similarly, select the Valve Characterizer box, also outlined in blue, to jump to the Manual Stroke/Linearization screen, also detailed below.

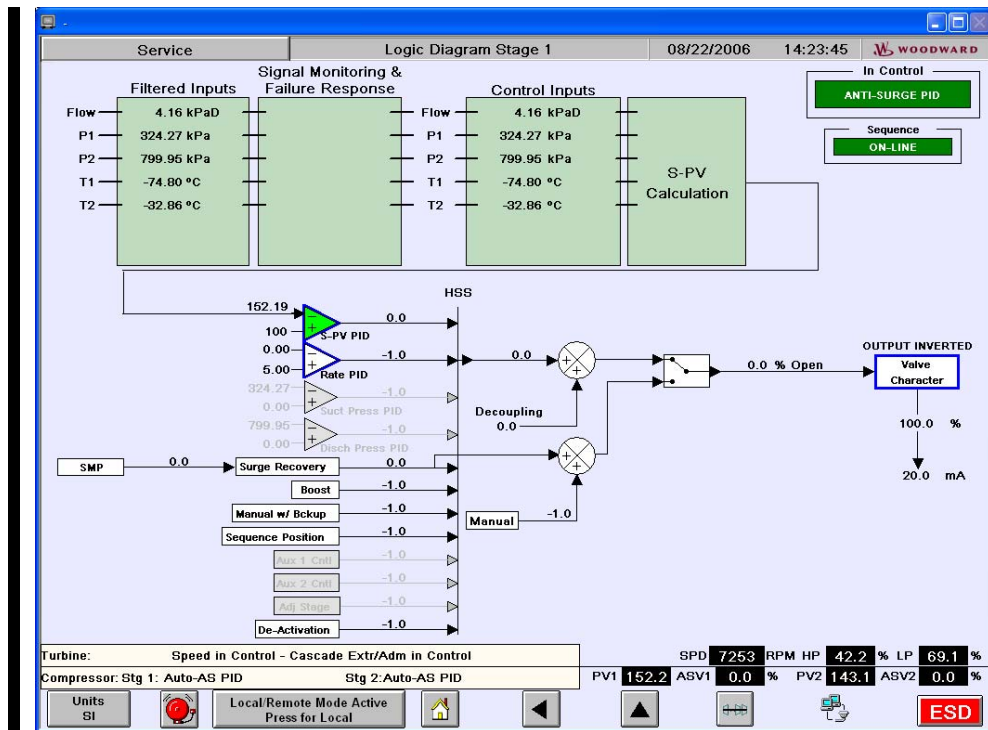

Figure 5-4. Compressor Logic Diagram Screen

## Compressor Dynamics Tuning Screens

Tuning of the various controllers is available via individual dynamics tuning screens accessible from the Logic Diagram screen shown in Figure 5-4. Select the desired PID amplifier, outlined in blue, to access the respective tuning screen. The Anti-Surge Dynamics tuning screen is shown in Figure 5-5. Similar screens are available for the Rate, Suction Pressure Override, and Discharge Pressure Override controllers.

The trend is configured with pens for the process variable, setpoint, and PID demand output. The trend window can be expanded or contracted in one-minute increments and the number of horizontal lines adjusted as desired. The crosshair, or cursor, can be moved to any location within the trend to verify pen values at that point. Below the trend, the minimum and maximum Y-axis limits for each pen can also be adjusted. The cursor values and current values are shown for each pen.

If the process cannot be manipulated, such as with a discharge block valve, the demand value to the right, in this case the base control margin, can be adjusted to introduce disturbances. Tune the proportional (P), integral (I), and derivative (SDR) values as necessary to achieve the desired control response (See the Dynamics Adjustments section in Chapter 4 for details on P-I-D settings and general tuning procedures).

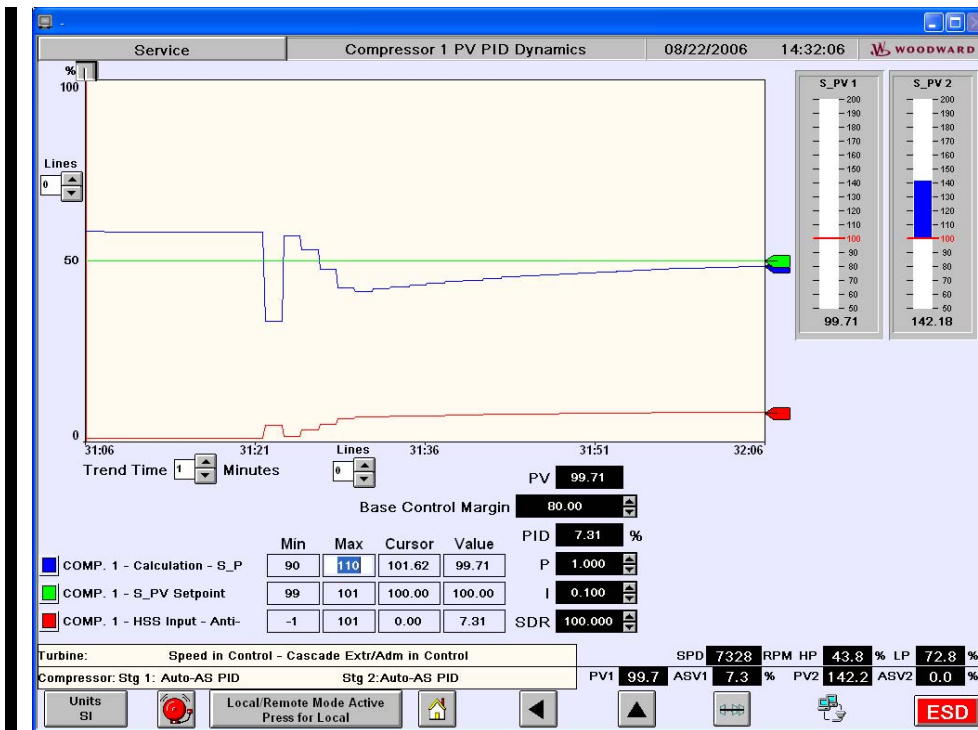
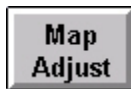

Figure 5-5. Compressor Anti-Surge PID Tuning Screen

## Compressor Stage 1 Map Screen (same for Stage 2)

The Compressor Map Screen is shown in Figure 5-6. The current compressor operation is reflected in the position of the dynamic operating point on the map. Pertinent operating data are shown to the right of the map. Adjust the number of horizontal and vertical lines as desired, perhaps to mimic the original compressor map from the manufacturer.



To adjust the appearance of the map (axes limits), any of the configured Surge Limit Line points, or the flow constant, select the Map Adjust button (available when logged-in at Engineering or higher).

The Map Adjust Pop-up, shown in Figure 5-7, facilitates customization of the map view and, more importantly, online adjustment of the Surge Limit Line and flow constant. The latter features are important if the configuration data used initially are known to be inaccurate or discovered so as part of normal operation of the unit.

As during initial configuration of the map, the X- and Y-axis limits can be adjusted as desired. This is often convenient to design the operating map to mimic the original from the manufacturer.

If the compressor has been surge-tested, or field-mapped, the original Surge Limit Line points may be found to be incorrect. Both the head and flow values for each of the five (5) points may be adjusted. Exercise caution if these points are to be modified on a running unit.



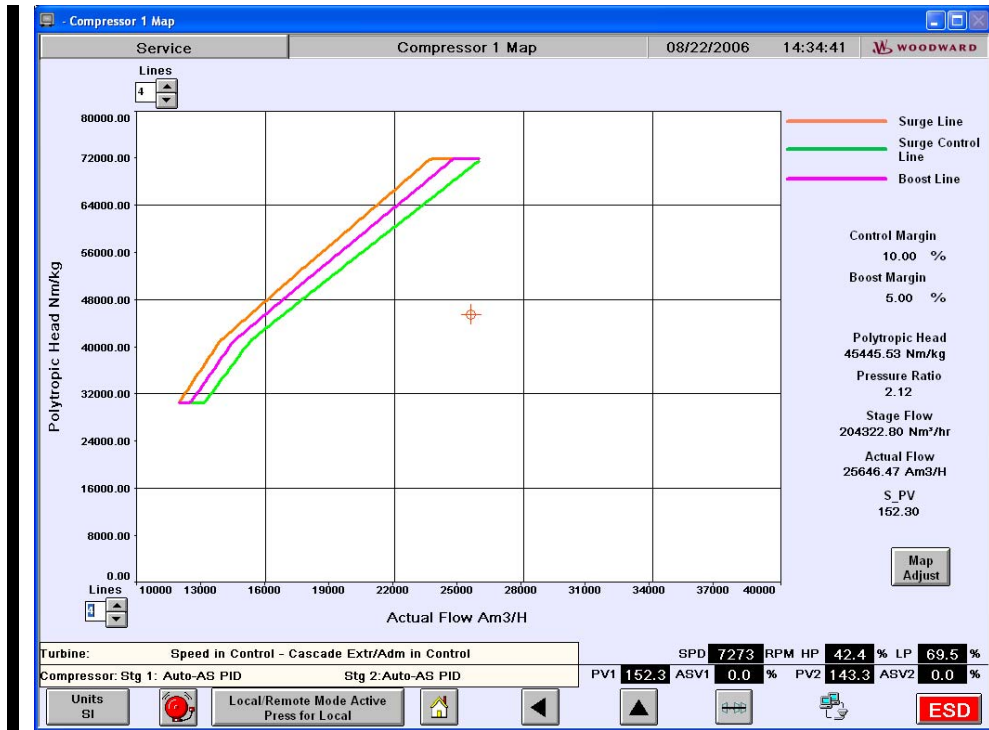

Figure 5-6. Compressor Map Screen

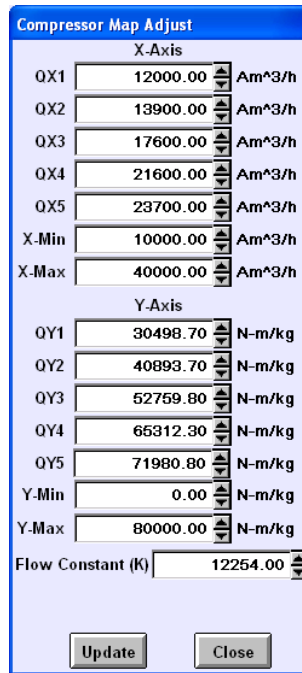

Figure 5-7. Compressor Map Adjust Pop-Up

If the 505CC-2's calculated flow is inaccurate, the flow constant (and polytropic exponent for the Universal Algorithm) may be adjusted here as well. If a known flow point exists, by comparison with another calibrated flow measurement, or by using compressor speed and head to reference flow on the original compressor map, the flow constant can be modified proportionally. For example, if the 505CC-2's calculated flow is 10% higher than a different, but known accurate measurement, reduce the flow constant by 9.09%.



If any value in the Map Adjust Pop-up is modified, press the Update button to redraw the map on the Map Screen.

## Compressor AS Valve Manual Stroke/Linearization Screen (same for Stage 2)

Due to the broad range of typical compressor operation, linear valves are preferred for anti-surge control. However, accurate linear characterizations are rare in all but premium sliding stem globe control valves. And, as line sizes increase, these valves quickly become cost and size prohibitive. As a result, less accurate rotary valves are common in anti-surge applications, especially as unit size increases. Regardless of the valve design, the 505CC-2 provides a linearization utility to characterize the control's demand output with the valve design to produce as linear a flow profile as possible.

The Anti-surge Valve Linearization Screen is shown in Figure 5-8. The security login must be Engineering or higher to permit valve stroking via this screen. In addition, functionality is limited to shutdown (zero speed) and normal, online operating conditions. In case of the former, enabling the linearization stroke will put the compressor control into Full Manual mode to allow stroking the valve for maintenance or testing purposes. If online, the mode is instead switched to Manual with Backup, and with flow, the linearization function is feasible, provided that the process and compressor operation is stable. If the unit is in a start-up or shutdown condition, as speed is ramping between minimum (zero) and online, valve stroking via this screen is inhibited. When enabled, adjustment buttons are provided to open and close the valve, as well as single-button commands to go fully open or fully closed.

The current, calculated stage flow is displayed for reference. While this flow measurement is that through the compressor, not through the valve, it is nonetheless related, and recycle flow can be inferred. With the unit online and at a stable operating point, and the anti-surge valve fully closed, note the calculated stage flow. Enable the linearization stroke, and open the valve fully. Again, once stable, note the compressor flow. The difference between these two flow values is the maximum anti-surge valve flow at the current operating conditions. Divide this value by ten (10) to yield a targeted flow rate per ten percent (10%) valve position increment. Position the valve at ten percent (10%) increments and adjust the linearization curve's corresponding Y-values to achieve the targeted flow increment. Disable the linearization stroke when complete.



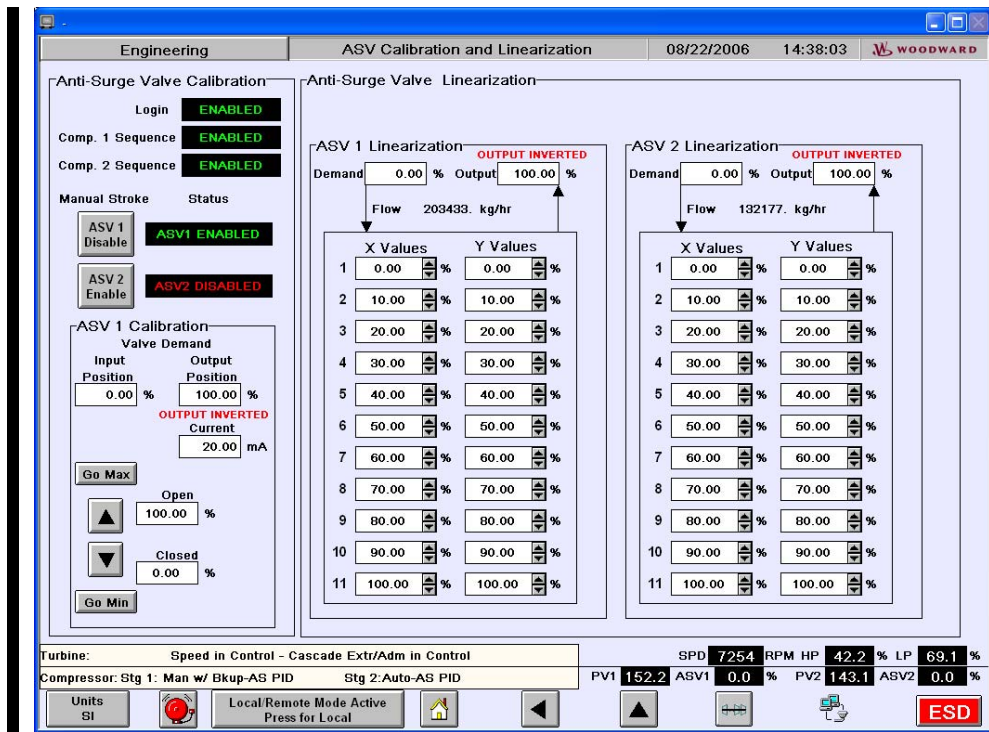

Figure 5-8. Compressor Anti-surge Valve Linearization Screen

## Chapter 6.

# Service Options

### Product Service Options

If you are experiencing problems with the installation, or unsatisfactory performance of a Woodward product, the following options are available:

- Consult the troubleshooting guide in the manual.
- Contact the manufacturer or packager of your system.
- Contact the Woodward Full Service Distributor serving your area.
- Contact Woodward technical assistance (see “How to Contact Woodward” later in this chapter) and discuss your problem. In many cases, your problem can be resolved over the phone. If not, you can select which course of action to pursue based on the available services listed in this chapter.

**OEM and Packager Support:** Many Woodward controls and control devices are installed into the equipment system and programmed by an Original Equipment Manufacturer (OEM) or Equipment Packager at their factory. In some cases, the programming is password-protected by the OEM or packager, and they are the best source for product service and support. Warranty service for Woodward products shipped with an equipment system should also be handled through the OEM or Packager. Please review your equipment system documentation for details.

**Woodward Business Partner Support:** Woodward works with and supports a global network of independent business partners whose mission is to serve the users of Woodward controls, as described here:

- A **Full Service Distributor** has the primary responsibility for sales, service, system integration solutions, technical desk support, and aftermarket marketing of standard Woodward products within a specific geographic area and market segment.
- An **Authorized Independent Service Facility (AISF)** provides authorized service that includes repairs, repair parts, and warranty service on Woodward's behalf. Service (not new unit sales) is an AISF's primary mission.
- A **Recognized Engine Retrofitter (RER)** is an independent company that does retrofits and upgrades on reciprocating gas engines and dual-fuel conversions, and can provide the full line of Woodward systems and components for the retrofits and overhauls, emission compliance upgrades, long term service contracts, emergency repairs, etc.
- A **Recognized Turbine Retrofitter (RTR)** is an independent company that does both steam and gas turbine control retrofits and upgrades globally, and can provide the full line of Woodward systems and components for the retrofits and overhauls, long term service contracts, emergency repairs, etc.

You can locate your nearest Woodward distributor, AISF, RER, or RTR on our website at:

[www.woodward.com/directory](http://www.woodward.com/directory)

## Woodward Factory Servicing Options

The following factory options for servicing Woodward products are available through your local Full-Service Distributor or the OEM or Packager of the equipment system, based on the standard Woodward Product and Service Warranty (5-01-1205) that is in effect at the time the product is originally shipped from Woodward or a service is performed:

- Replacement/Exchange (24-hour service)
- Flat Rate Repair
- Flat Rate Remanufacture

**Replacement/Exchange:** Replacement/Exchange is a premium program designed for the user who is in need of immediate service. It allows you to request and receive a like-new replacement unit in minimum time (usually within 24 hours of the request), providing a suitable unit is available at the time of the request, thereby minimizing costly downtime. This is a flat-rate program and includes the full standard Woodward product warranty (Woodward Product and Service Warranty 5-01-1205).

This option allows you to call your Full-Service Distributor in the event of an unexpected outage, or in advance of a scheduled outage, to request a replacement control unit. If the unit is available at the time of the call, it can usually be shipped out within 24 hours. You replace your field control unit with the like-new replacement and return the field unit to the Full-Service Distributor.

Charges for the Replacement/Exchange service are based on a flat rate plus shipping expenses. You are invoiced the flat rate replacement/exchange charge plus a core charge at the time the replacement unit is shipped. If the core (field unit) is returned within 60 days, a credit for the core charge will be issued.

**Flat Rate Repair:** Flat Rate Repair is available for the majority of standard products in the field. This program offers you repair service for your products with the advantage of knowing in advance what the cost will be. All repair work carries the standard Woodward service warranty (Woodward Product and Service Warranty 5-01-1205) on replaced parts and labor.

**Flat Rate Remanufacture:** Flat Rate Remanufacture is very similar to the Flat Rate Repair option with the exception that the unit will be returned to you in “like-new” condition and carry with it the full standard Woodward product warranty (Woodward Product and Service Warranty 5-01-1205). This option is applicable to mechanical products only.

## Returning Equipment for Repair

If a control (or any part of an electronic control) is to be returned for repair, please contact your Full-Service Distributor in advance to obtain Return Authorization and shipping instructions.

When shipping the item(s), attach a tag with the following information:

- return authorization number;
- name and location where the control is installed;
- name and phone number of contact person;
- complete Woodward part number(s) and serial number(s);
- description of the problem;
- instructions describing the desired type of repair.

## Packing a Control

Use the following materials when returning a complete control:

- protective caps on any connectors;
- antistatic protective bags on all electronic modules;
- packing materials that will not damage the surface of the unit;
- at least 100 mm (4 inches) of tightly packed, industry-approved packing material;
- a packing carton with double walls;
- a strong tape around the outside of the carton for increased strength.

### NOTICE

To prevent damage to electronic components caused by improper handling, read and observe the precautions in Woodward manual 82715, *Guide for Handling and Protection of Electronic Controls, Printed Circuit Boards, and Modules*.

## Replacement Parts

When ordering replacement parts for controls, include the following information:

- the part number(s) (XXXX-XXXX) that is on the enclosure nameplate;
- the unit serial number, which is also on the nameplate.

## Engineering Services

Woodward offers various Engineering Services for our products. For these services, you can contact us by telephone, by email, or through the Woodward website.

- Technical Support
- Product Training
- Field Service

**Technical Support** is available from your equipment system supplier, your local Full-Service Distributor, or from many of Woodward's worldwide locations, depending upon the product and application. This service can assist you with technical questions or problem solving during the normal business hours of the Woodward location you contact. Emergency assistance is also available during non-business hours by phoning Woodward and stating the urgency of your problem.

**Product Training** is available as standard classes at many of our worldwide locations. We also offer customized classes, which can be tailored to your needs and can be held at one of our locations or at your site. This training, conducted by experienced personnel, will assure that you will be able to maintain system reliability and availability.

**Field Service** engineering on-site support is available, depending on the product and location, from many of our worldwide locations or from one of our Full-Service Distributors. The field engineers are experienced both on Woodward products as well as on much of the non-Woodward equipment with which our products interface.

For information on these services, please contact us via telephone, email us, or use our website: [www.woodward.com](http://www.woodward.com).

## How to Contact Woodward

For assistance, call one of the following Woodward facilities to obtain the address and phone number of the facility nearest your location where you will be able to get information and service.

### Electrical Power Systems

Facility	Phone Number
Brazil	+55 (19) 3708 4800
China	+86 (512) 6762 6727
Germany	+49 (0) 21 52 14 51
India	+91 (129) 4097100
Japan	+81 (43) 213-2191
Korea	+82 (51) 636-7080
Poland	+48 12 295 13 00
United States	+1 (970) 482-5811

### Engine Systems

Facility	Phone Number
Brazil	+55 (19) 3708 4800
China	+86 (512) 6762 6727
Germany	+49 (711) 78954-510
India	+91 (129) 4097100
Japan	+81 (43) 213-2191
Korea	+82 (51) 636-7080
The Netherlands	+31 (23) 5661111
United States	+1 (970) 482-5811

### Turbine Systems

Facility	Phone Number
Brazil	+55 (19) 3708 4800
China	+86 (512) 6762 6727
India	+91 (129) 4097100
Japan	+81 (43) 213-2191
Korea	+82 (51) 636-7080
The Netherlands	+31 (23) 5661111
Poland	+48 12 295 13 00
United States	+1 (970) 482-5811

You can also locate your nearest Woodward distributor or service facility on our website at:

[www.woodward.com/directory](http://www.woodward.com/directory)

## Technical Assistance

If you need to telephone for technical assistance, you will need to provide the following information. Please write it down here before phoning:

Your Name \_\_\_\_\_

Site Location \_\_\_\_\_

Phone Number \_\_\_\_\_

Fax Number \_\_\_\_\_

---

Engine/Turbine Model Number \_\_\_\_\_

Manufacturer \_\_\_\_\_

Number of Cylinders (if applicable) \_\_\_\_\_

Type of Fuel (gas, gaseous, steam, etc) \_\_\_\_\_

Rating \_\_\_\_\_

Application \_\_\_\_\_

---

**Control/Governor #1**

Woodward Part Number & Rev. Letter \_\_\_\_\_

Control Description or Governor Type \_\_\_\_\_

Serial Number \_\_\_\_\_

---

**Control/Governor #2**

Woodward Part Number & Rev. Letter \_\_\_\_\_

Control Description or Governor Type \_\_\_\_\_

Serial Number \_\_\_\_\_

---

**Control/Governor #3**

Woodward Part Number & Rev. Letter \_\_\_\_\_

Control Description or Governor Type \_\_\_\_\_

Serial Number \_\_\_\_\_

*If you have an electronic or programmable control, please have the adjustment setting positions or the menu settings written down and with you at the time of the call.*

# Appendix A.

## Valid Compressor Configurations

The following tables and figures can be used to review a particular configuration, from the Comp General configuration screen, as valid or invalid. If a configuration variable is not shown in the chart, it does not impact that layout. The 505CC-2 will generate an error message for invalid configurations but will not automatically correct or pinpoint the problem.

### Standard Algorithm / Single Stage

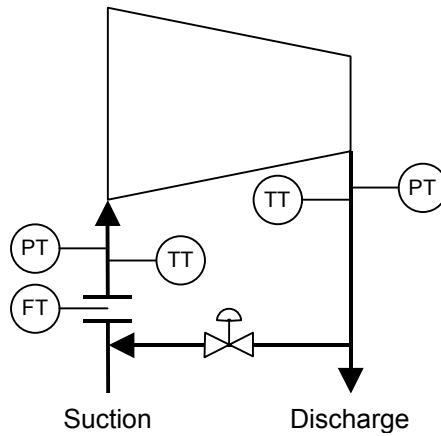

Gas Component	Flow Element	Temperature Sensor	Number of Valves	Config.
Constant	Suction	Suct. + Disch.	1	Valid
		Suct.	1	Valid
		Disch.	1	-
	Discharge	Suct. + Disch.	1	Valid
		Suct.	1	-
		Disch.	1	Valid

Gas Component	Flow Element	Temperature Sensor	Number of Valves	Config.
Variable	Suction	Suct. + Disch.	1	Valid
		Suct.	1	-
		Disch.	1	-
	Discharge	Suct. + Disch.	1	Valid
		Suct.	1	-
		Disch.	1	-

Figure A-1. Standard Algorithm, Single Stage Configurations

Standard Algorithm / Dual with 1 Flow Element

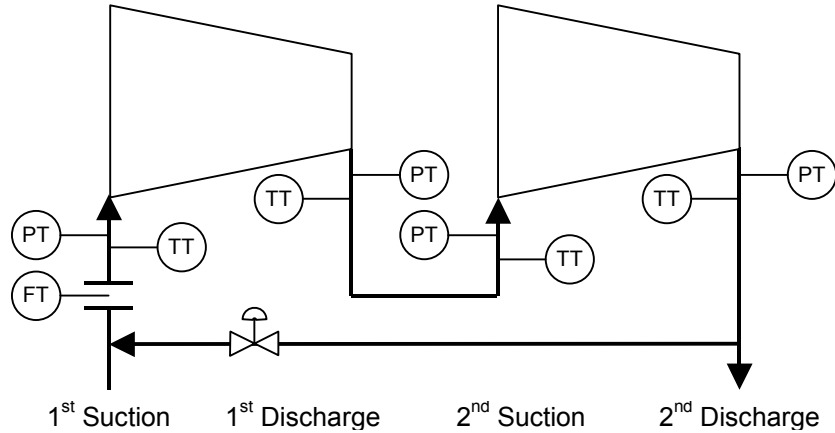

Gas Component	Flow Element	Temperature Sensor	Number of Valve	Config.
Constant	1st Suct.	(Suct. + Disch.) + (Suct. + Disch.)	1	Valid
		(Suct. + Disch.) + (Suct.)	1	Valid
		(Suct. + Disch.) + (Disch.)	1	Valid
		(Suct.) + (Suct. + Disch.)	1	Valid
		(Disch.) + (Suct. + Disch.)	1	-
		(Suct.) + (Suct.)	1	Valid
		(Suct.) + (Disch.)	1	Valid
		(Disch.) + (Suct.)	1	-
	1st Disch.	(Suct. + Disch.) + (Suct. + Disch.)	1	Valid
		(Suct. + Disch.) + (Suct.)	1	Valid
		(Suct. + Disch.) + (Disch.)	1	Valid
		(Suct.) + (Suct. + Disch.)	1	-
		(Disch.) + (Suct. + Disch.)	1	Valid
		(Suct.) + (Suct.)	1	-
		(Suct.) + (Disch.)	1	-
		(Disch.) + (Suct.)	1	Valid
	2nd Suct.	(Suct. + Disch.) + (Suct. + Disch.)	1	Valid
		(Suct. + Disch.) + (Suct.)	1	Valid
		(Suct. + Disch.) + (Disch.)	1	-
		(Suct.) + (Suct. + Disch.)	1	Valid
		(Disch.) + (Suct. + Disch.)	1	Valid
		(Suct.) + (Suct.)	1	Valid
		(Suct.) + (Disch.)	1	-
		(Disch.) + (Suct.)	1	Valid
	2nd Disch.	(Suct. + Disch.) + (Suct. + Disch.)	1	Valid
		(Suct. + Disch.) + (Suct.)	1	-
		(Suct. + Disch.) + (Disch.)	1	Valid
		(Suct.) + (Suct. + Disch.)	1	Valid
		(Disch.) + (Suct. + Disch.)	1	Valid
		(Suct.) + (Suct.)	1	-
		(Suct.) + (Disch.)	1	Valid
		(Disch.) + (Suct.)	1	-
(Disch.) + (Disch.)	1	Valid		

Figure A-2a. Standard Algorithm, Dual with 1 Flow Element Configurations

Gas Component	Flow Element	Temperature Sensor	Number of Valve	Config.
Variable	1st Suct.	(Suct. + Disch.) + (Suct. + Disch.)	1	Valid
		(Suct. + Disch.) + (Suct.)	1	-
		(Suct. + Disch.) + (Disch.)	1	-
		(Suct.) + (Suct. + Disch.)	1	-
		(Disch.) + (Suct. + Disch.)	1	-
		(Suct.) + (Suct.)	1	-
		(Suct.) + (Disch.)	1	-
		(Disch.) + (Suct.)	1	-
	(Disch.) + (Disch.)	1	-	
	1st Disch.	(Suct. + Disch.) + (Suct. + Disch.)	1	Valid
		(Suct. + Disch.) + (Suct.)	1	-
		(Suct. + Disch.) + (Disch.)	1	-
		(Suct.) + (Suct. + Disch.)	1	-
		(Disch.) + (Suct. + Disch.)	1	-
		(Suct.) + (Suct.)	1	-
		(Suct.) + (Disch.)	1	-
		(Disch.) + (Suct.)	1	-
	(Disch.) + (Disch.)	1	-	
	2nd Suct.	(Suct. + Disch.) + (Suct. + Disch.)	1	Valid
		(Suct. + Disch.) + (Suct.)	1	-
		(Suct. + Disch.) + (Disch.)	1	-
		(Suct.) + (Suct. + Disch.)	1	-
		(Disch.) + (Suct. + Disch.)	1	-
		(Suct.) + (Suct.)	1	-
		(Suct.) + (Disch.)	1	-
		(Disch.) + (Suct.)	1	-
	(Disch.) + (Disch.)	1	-	
	2nd Disch.	(Suct. + Disch.) + (Suct. + Disch.)	1	Valid
		(Suct. + Disch.) + (Suct.)	1	-
		(Suct. + Disch.) + (Disch.)	1	-
		(Suct.) + (Suct. + Disch.)	1	-
		(Disch.) + (Suct. + Disch.)	1	-
		(Suct.) + (Suct.)	1	-
		(Suct.) + (Disch.)	1	-
		(Disch.) + (Suct.)	1	-
	(Disch.) + (Disch.)	1	-	

Figure A-2b. Standard Algorithm, Dual with 1 Flow Element Configurations



Standard Algorithm / Dual with 2 Flow Elements

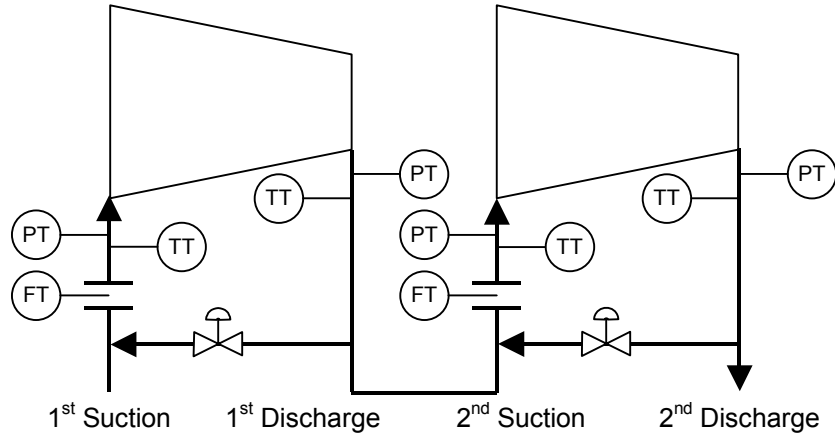

Gas Component	Flow Element	Temperature Sensor	Number of Valve	Config.
Constant	1st Suct. + 2nd Suct.	(Suct. + Disch.) + (Suct. + Disch.)	2 or 1	Valid
		(Suct. + Disch.) + (Suct.)	2 or 1	Valid
		(Suct. + Disch.) + (Disch.)	2 or 1	-
		(Suct.) + (Suct. + Disch.)	2 or 1	Valid
		(Disch.) + (Suct. + Disch.)	2 or 1	-
		(Suct.) + (Suct.)	2 or 1	Valid
		(Suct.) + (Disch.)	2 or 1	-
		(Disch.) + (Suct.)	2 or 1	-
		(Disch.) + (Disch.)	2 or 1	-
	1st Suct. + 2nd Disch.	(Suct. + Disch.) + (Suct. + Disch.)	2 or 1	Valid
		(Suct. + Disch.) + (Suct.)	2 or 1	-
		(Suct. + Disch.) + (Disch.)	2 or 1	Valid
		(Suct.) + (Suct. + Disch.)	2 or 1	Valid
		(Disch.) + (Suct. + Disch.)	2 or 1	-
		(Suct.) + (Suct.)	2 or 1	-
		(Suct.) + (Disch.)	2 or 1	Valid
		(Disch.) + (Suct.)	2 or 1	-
		(Disch.) + (Disch.)	2 or 1	-
	1st Disch. + 2nd Suct.	(Suct. + Disch.) + (Suct. + Disch.)	2 or 1	Valid
		(Suct. + Disch.) + (Suct.)	2 or 1	Valid
		(Suct. + Disch.) + (Disch.)	2 or 1	-
		(Suct.) + (Suct. + Disch.)	2 or 1	-
		(Disch.) + (Suct. + Disch.)	2 or 1	Valid
		(Suct.) + (Suct.)	2 or 1	-
		(Suct.) + (Disch.)	2 or 1	-
		(Disch.) + (Suct.)	2 or 1	Valid
		(Disch.) + (Disch.)	2 or 1	-
	1st Disch. + 2nd Disch.	(Suct. + Disch.) + (Suct. + Disch.)	2 or 1	Valid
		(Suct. + Disch.) + (Suct.)	2 or 1	-
		(Suct. + Disch.) + (Disch.)	2 or 1	Valid
		(Suct.) + (Suct. + Disch.)	2 or 1	-
		(Disch.) + (Suct. + Disch.)	2 or 1	Valid
		(Suct.) + (Suct.)	2 or 1	-
		(Suct.) + (Disch.)	2 or 1	-
		(Disch.) + (Suct.)	2 or 1	-
		(Disch.) + (Disch.)	2 or 1	Valid

Figure A-3a. Standard Algorithm, Dual with 2 Flow Element Configurations

Gas Component	Flow Element	Temperature Sensor	Number of Valve	Config.
Variable	1st Suct. + 2nd Suct.	(Suct. + Disch.) + (Suct. + Disch.)	2 or 1	Valid
		(Suct. + Disch.) + (Suct.)	2 or 1	-
		(Suct. + Disch.) + (Disch.)	2 or 1	-
		(Suct.) + (Suct. + Disch.)	2 or 1	-
		(Disch.) + (Suct. + Disch.)	2 or 1	-
		(Suct.) + (Suct.)	2 or 1	-
		(Suct.) + (Disch.)	2 or 1	-
		(Disch.) + (Suct.)	2 or 1	-
	1st Suct. + 2nd Disch.	(Suct. + Disch.) + (Suct. + Disch.)	2 or 1	Valid
		(Suct. + Disch.) + (Suct.)	2 or 1	-
		(Suct. + Disch.) + (Disch.)	2 or 1	-
		(Suct.) + (Suct. + Disch.)	2 or 1	-
		(Disch.) + (Suct. + Disch.)	2 or 1	-
		(Suct.) + (Suct.)	2 or 1	-
		(Suct.) + (Disch.)	2 or 1	-
		(Disch.) + (Suct.)	2 or 1	-
	1st Disch. + 2nd Suct.	(Suct. + Disch.) + (Suct. + Disch.)	2 or 1	Valid
		(Suct. + Disch.) + (Suct.)	2 or 1	-
		(Suct. + Disch.) + (Disch.)	2 or 1	-
		(Suct.) + (Suct. + Disch.)	2 or 1	-
		(Disch.) + (Suct. + Disch.)	2 or 1	-
		(Suct.) + (Suct.)	2 or 1	-
		(Suct.) + (Disch.)	2 or 1	-
		(Disch.) + (Suct.)	2 or 1	-
	1st Disch. + 2nd Disch.	(Suct. + Disch.) + (Suct. + Disch.)	2 or 1	Valid
		(Suct. + Disch.) + (Suct.)	2 or 1	-
		(Suct. + Disch.) + (Disch.)	2 or 1	-
		(Suct.) + (Suct. + Disch.)	2 or 1	-
		(Disch.) + (Suct. + Disch.)	2 or 1	-
		(Suct.) + (Suct.)	2 or 1	-
		(Suct.) + (Disch.)	2 or 1	-
		(Disch.) + (Suct.)	2 or 1	-

Figure A-3b. Standard Algorithm, Dual with 2 Flow Element Configurations

Standard Algorithm / Dual with Sidestream

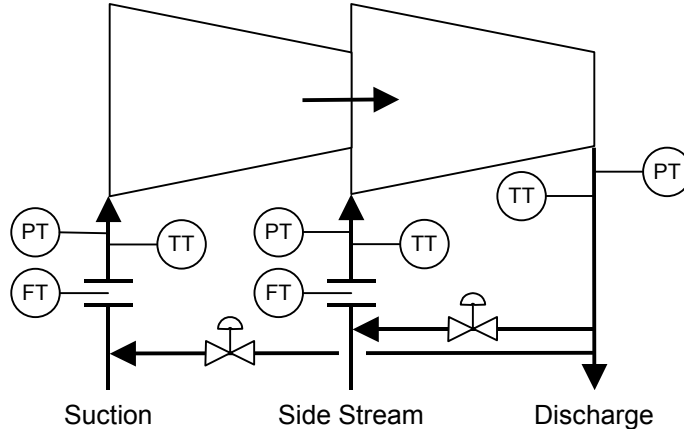

Gas Component	S.S. Direction	Flow Element	Temperature Sensor	Number of Valve	Config.	
Constant	Admission	Suct. + S.S.	(Suct.) + (S.S. + Disch.)	2 or 1	Valid	
			(Suct.) + (S.S.)	2 or 1	Valid	
			(Suct.) + (Disch.)	2 or 1	-	
		Suct. + Disch.	(Suct.) + (S.S. + Disch.)	2 or 1	Valid	
			(Suct.) + (S.S.)	2 or 1	-	
			(Suct.) + (Disch.)	2 or 1	Valid	
	S.S. + Disch.	(Suct.) + (S.S. + Disch.)	2 or 1	Valid		
		(Suct.) + (S.S.)	2 or 1	-		
		(Suct.) + (Disch.)	2 or 1	-		
		Extraction	Suct. + S.S.	(Suct.) + (S.S. + Disch.)	2 or 1	Valid
				(Suct.) + (S.S.)	2 or 1	Valid
				(Suct.) + (Disch.)	2 or 1	-
Suct. + Disch.	(Suct.) + (S.S. + Disch.)		2 or 1	Valid		
	(Suct.) + (S.S.)		2 or 1	-		
	(Suct.) + (Disch.)		2 or 1	Valid		
S.S. + Disch.	(Suct.) + (S.S. + Disch.)	2 or 1	Valid			
	(Suct.) + (S.S.)	2 or 1	-			
	(Suct.) + (Disch.)	2 or 1	-			

Gas Component	S.S. Direction	Flow Element	Temperature Sensor	Number of Valve	Config.	
Variable	Admission	Suct. + S.S.	(Suct.) + (S.S. + Disch.)	2 or 1	-	
			(Suct.) + (S.S.)	2 or 1	-	
			(Suct.) + (Disch.)	2 or 1	-	
		Suct. + Disch.	(Suct.) + (S.S. + Disch.)	2 or 1	-	
			(Suct.) + (S.S.)	2 or 1	-	
			(Suct.) + (Disch.)	2 or 1	-	
	S.S. + Disch.	(Suct.) + (S.S. + Disch.)	2 or 1	-		
		(Suct.) + (S.S.)	2 or 1	-		
		(Suct.) + (Disch.)	2 or 1	-		
		Extraction	Suct. + S.S.	(Suct.) + (S.S. + Disch.)	2 or 1	-
				(Suct.) + (S.S.)	2 or 1	-
				(Suct.) + (Disch.)	2 or 1	-
	Suct. + Disch.		(Suct.) + (S.S. + Disch.)	2 or 1	-	
			(Suct.) + (S.S.)	2 or 1	-	
			(Suct.) + (Disch.)	2 or 1	-	
	S.S. + Disch.		(Suct.) + (S.S. + Disch.)	2 or 1	-	
			(Suct.) + (S.S.)	2 or 1	-	
			(Suct.) + (Disch.)	2 or 1	-	

Figure A-4. Standard Algorithm, Dual with SideStream Configurations

**Universal Algorithm / Single Stage**

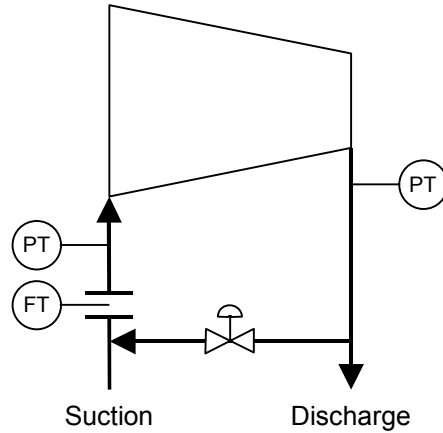

Flow Element	Number of Valve	Config.
Suction	1	Valid
Discharge	1	Valid

Figure A-5. Universal Algorithm, Single Stage Configurations

**Universal Algorithm / Dual with 2 Flow Elements**

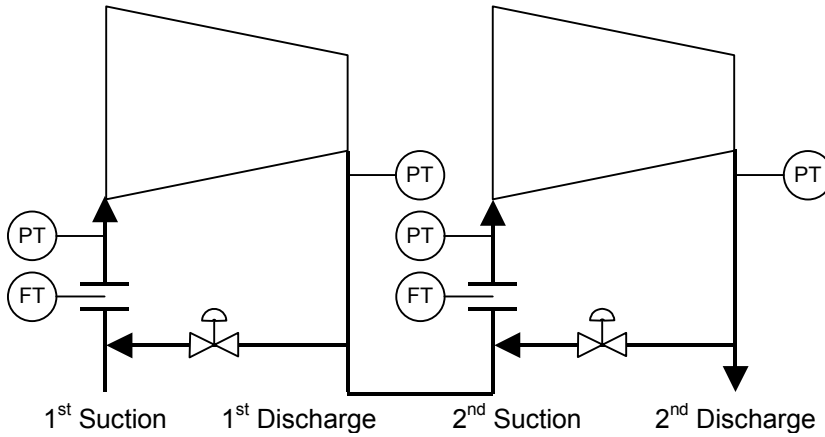

Flow Element	Number of Valve	Config.
1st Suct. + 2nd Suct.	1	Valid
	2	Valid
1st Suct. + 2nd Disch.	1	Valid
	2	Valid
1st Disch. + 2nd Suct.	1	Valid
	2	Valid
1st Disch. + 2nd Disch.	1	Valid
	2	Valid

Figure A-6. Universal Algorithm, Dual with 2 Flow Element Configurations

Universal Algorithm / Dual with Sidestream

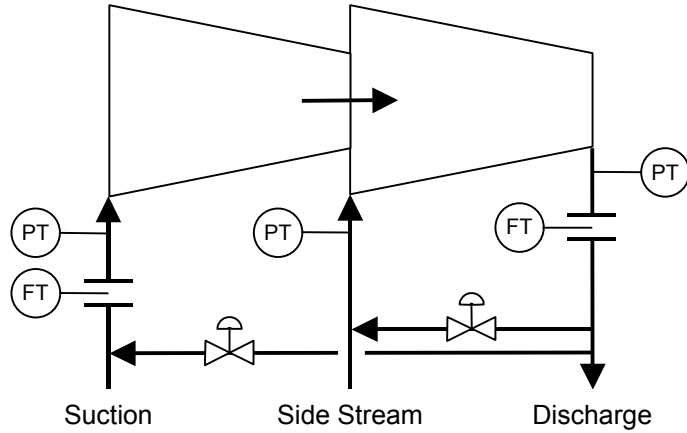

Flow Element	Number of Valve	Config.
1st Suct. + 2nd Disch.	1	Valid
	2	Valid
Side Stream + 2nd Disch.	1	-
	2	-
1st Suct. + Side Stream	1	-
	2	-

Figure A-7. Universal Algorithm, Dual with SideStream Configurations

## Appendix B.

# Atmospheric Pressure Chart

Altitude Above Mean Sea Level		Atmospheric Pressure	
Feet	Meters	psiA	kPaA
0	0.0	14.70	101.33
500	152.4	14.43	99.49
1000	304.8	14.16	97.63
1500	457.2	13.91	95.91
2000	609.6	13.66	94.19
2500	762.0	13.41	92.46
3000	914.4	13.17	90.81
3500	1066.8	12.93	89.15
4000	1219.2	12.69	87.50
4500	1371.6	12.46	85.91
5000	1524.0	12.23	84.33
6000	1828.8	11.78	81.22
7000	2133.6	11.34	78.19
8000	2438.4	10.91	75.22
9000	2743.2	10.50	72.40
10000	3048.0	10.10	69.64
15000	4572.0	8.29	57.16

Table B-1. Atmospheric Pressure Chart





**We appreciate your comments about the content of our publications.**

**Send comments to: [icinfo@woodward.com](mailto:icinfo@woodward.com)**

**Please reference publication **26240V3B**.**



PO Box 1519, Fort Collins CO 80522-1519, USA  
1000 East Drake Road, Fort Collins CO 80525, USA  
Phone +1 (970) 482-5811 • Fax +1 (970) 498-3058

**Email and Website—[www.woodward.com](http://www.woodward.com)**

**Woodward has company-owned plants, subsidiaries, and branches,  
as well as authorized distributors and other authorized service and sales facilities throughout the world.**

**Complete address / phone / fax / email information for all locations is available on our website.**